

INSTRUCTION MANUAL



# Cordless Chain Saw

**UC002G**

**UC003G**

**UC004G**

**UC006G**

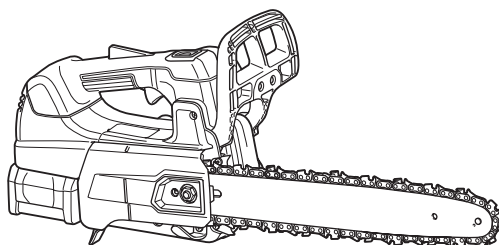

Read before use.

# SPECIFICATIONS

Model:		UC002G	UC003G	UC004G	UC006G
Overall length (without guide bar and battery)		266 mm			
Rated voltage		D.C. 36 V - 40 V max			
Net weight	*1	2.6 kg			
	*2	3.8 - 4.5 kg	3.9 - 4.6 kg	4.0 - 4.7 kg	3.9 - 4.5 kg
Standard guide bar length		250 mm	300 mm	350 mm	250 mm
Recommended guide bar length	with 90PX	250 - 350 mm			-
	with 91PX	250 - 350 mm			-
	with 25AP	-			250 mm
Applicable saw chain type (refer to the table below)		90PX 91PX		25AP	
Standard sprocket	Number of teeth	6			9
	Pitch	3/8"			1/4"
Chain speed		0 - 24.8 m/s (0 - 1,490 m/min)			
Chain oil tank volume		200 cm <sup>3</sup>			
Protection degree		IPX4			

- Due to our continuing program of research and development, the specifications herein are subject to change without notice.
  - Specifications may differ from country to country.
- \*1: Weight, without the saw chain, guide bar, guide bar cover, oil and battery cartridge(s).  
 \*2: The lightest and heaviest combination of weight, according to EPTA-Procedure 01/2014. The weight may differ depending on the attachment(s), including the battery cartridge(s).

## Applicable battery cartridge and charger

Battery cartridge	BL4020 / BL4025* / BL4040* / BL4050F * : Recommended battery
Charger	DC40RA / DC40RB / DC40RC

- Some of the battery cartridges and chargers listed above may not be available depending on your region of residence.

**⚠ WARNING:** Only use the battery cartridges and chargers listed above. Use of any other battery cartridges and chargers may cause injury and/or fire.

**NOTE:** We recommend using the recommended batteries to fully obtain the performance of this tool.

## Saw chain, guide bar, and sprocket combination

Saw chain type		90PX		
Number of drive links		40	46	52
Guide bar	Guide bar length	250 mm	300 mm	350 mm
	Cutting length	225 mm	281 mm	337 mm
	Pitch	3/8"		
	Gauge	1.1 mm		
	Type	Sprocket nose bar		
Sprocket	Number of teeth	6		
	Pitch	3/8"		

Saw chain type		91PX		
Number of drive links		40	46	52
Guide bar	Guide bar length	250 mm	300 mm	350 mm
	Cutting length	225 mm	281 mm	337 mm
	Pitch	3/8"		
	Gauge	1.3 mm		
	Type	Sprocket nose bar		
Sprocket	Number of teeth	6		
	Pitch	3/8"		

Saw chain type		25AP		
Number of drive links		60		
Guide bar	Guide bar length	250 mm		
	Cutting length	239 mm		
	Pitch	1/4"		
	Gauge	1.3 mm		
	Type	Carving bar		
Sprocket	Number of teeth	9		
	Pitch	1/4"		

**⚠ WARNING:** Use appropriate combination of the guide bar and saw chain. Otherwise personal injury may result.

## Symbols

The followings show the symbols which may be used for the equipment. Be sure that you understand their meaning before use.

	Read instruction manual.
	Wear safety glasses.
	Wear ear protection.
	Wear a helmet, goggles and ear protection.
	Use appropriate protection for foot-leg and hand-arm.
	This saw is to be used by properly trained operators only.
	Do not expose to moisture.
	Maximum permissible cut length
	Always use two hands when operating the chain saw.
	Beware of chain saw kickback and avoid contact with bar tip.
	Direction of chain travel



## Saw chain oil adjustment



Only for EU countries

Due to the presence of hazardous components in the equipment, waste electrical and electronic equipment, accumulators and batteries may have a negative impact on the environment and human health. Do not dispose of electrical and electronic appliances or batteries with household waste!

In accordance with the European Directive on waste electrical and electronic equipment and on accumulators and batteries, as well as their adaptation to national law, waste electrical equipment, batteries and accumulators should be stored separately and delivered to a separate collection point for municipal waste, operating in accordance with the regulations on environmental protection.

This is indicated by the symbol of the crossed-out wheeled bin placed on the equipment.



Guaranteed sound power level according to EU Outdoor Noise Directive.



Sound power level according to Australia NSW Noise Control Regulation.

## Intended use

The tool is intended for cutting branches and pruning trees. It is also suitable for tree service.

## Noise

The typical A-weighted noise level determined according to EN62841-1 and EN ISO 11681-2 as applicable:

### Model UC002G

Sound pressure level ( $L_{pA}$ ): 90 dB(A)

Sound power level ( $L_{WA}$ ): 101 dB (A)

Uncertainty (K): 3 dB(A)

### Model UC003G

Sound pressure level ( $L_{pA}$ ): 90 dB(A)

Sound power level ( $L_{WA}$ ): 101 dB (A)

Uncertainty (K): 3 dB(A)

### Model UC004G

Sound pressure level ( $L_{pA}$ ): 90 dB(A)

Sound power level ( $L_{WA}$ ): 101 dB (A)

Uncertainty (K): 3 dB(A)

### Model UC006G

Sound pressure level ( $L_{pA}$ ): 88 dB(A)

Sound power level ( $L_{WA}$ ): 99 dB (A)

Uncertainty (K): 3 dB(A)

**NOTE:** The declared noise emission value(s) has been measured in accordance with a standard test method and may be used for comparing one tool with another.

**NOTE:** The declared noise emission value(s) may also be used in a preliminary assessment of exposure.

**⚠ WARNING:** Wear ear protection.

**⚠ WARNING:** The noise emission during actual use of the power tool can differ from the declared value(s) depending on the ways in which the tool is used especially what kind of workpiece is processed.

**⚠ WARNING:** Be sure to identify safety measures to protect the operator that are based on an estimation of exposure in the actual conditions of use (taking account of all parts of the operating cycle such as the times when the tool is switched off and when it is running idle in addition to the trigger time).

## Vibration

The vibration total value (tri-axial vector sum) determined according to EN62841-1 and EN ISO 11681-2 as applicable:

### Model UC002G

Work mode: cutting wood

Vibration emission ( $a_{h,w}$ ): 5.0 m/s<sup>2</sup>

Uncertainty (K): 1.5 m/s<sup>2</sup>

### Model UC003G

Work mode: cutting wood

Vibration emission ( $a_{h,w}$ ): 5.0 m/s<sup>2</sup>

Uncertainty (K): 1.5 m/s<sup>2</sup>

### Model UC004G

Work mode: cutting wood

Vibration emission ( $a_{h,w}$ ): 5.0 m/s<sup>2</sup>

Uncertainty (K): 1.5 m/s<sup>2</sup>

### Model UC006G

Work mode: cutting wood

Vibration emission ( $a_{h,w}$ ): 2.8 m/s<sup>2</sup>

Uncertainty (K): 1.5 m/s<sup>2</sup>

**NOTE:** The declared vibration total value(s) has been measured in accordance with a standard test method and may be used for comparing one tool with another.

**NOTE:** The declared vibration total value(s) may also be used in a preliminary assessment of exposure.

**⚠ WARNING:** The vibration emission during actual use of the power tool can differ from the declared value(s) depending on the ways in which the tool is used especially what kind of workpiece is processed.

**⚠ WARNING:** Be sure to identify safety measures to protect the operator that are based on an estimation of exposure in the actual conditions of use (taking account of all parts of the operating cycle such as the times when the tool is switched off and when it is running idle in addition to the trigger time).

## EC Declaration of Conformity

### For European countries only

The EC declaration of conformity is included as Annex A to this instruction manual.

## SAFETY WARNINGS

### General power tool safety warnings

**⚠ WARNING:** Read all safety warnings, instructions, illustrations and specifications provided with this power tool. Failure to follow all instructions listed below may result in electric shock, fire and/or serious injury.

### Save all warnings and instructions for future reference.

The term "power tool" in the warnings refers to your mains-operated (corded) power tool or battery-operated (cordless) power tool.

#### Work area safety

1. **Keep work area clean and well lit.** Cluttered or dark areas invite accidents.
2. **Do not operate power tools in explosive atmospheres, such as in the presence of flammable liquids, gases or dust.** Power tools create sparks which may ignite the dust or fumes.
3. **Keep children and bystanders away while operating a power tool.** Distractions can cause you to lose control.

#### Electrical safety

1. **Power tool plugs must match the outlet. Never modify the plug in any way. Do not use any adapter plugs with earthed (grounded) power tools.** Unmodified plugs and matching outlets will reduce risk of electric shock.
2. **Avoid body contact with earthed or grounded surfaces, such as pipes, radiators, ranges and refrigerators.** There is an increased risk of electric shock if your body is earthed or grounded.

3. **Do not expose power tools to rain or wet conditions.** Water entering a power tool will increase the risk of electric shock.
4. **Do not abuse the cord. Never use the cord for carrying, pulling or unplugging the power tool. Keep cord away from heat, oil, sharp edges or moving parts.** Damaged or entangled cords increase the risk of electric shock.
5. **When operating a power tool outdoors, use an extension cord suitable for outdoor use.** Use of a cord suitable for outdoor use reduces the risk of electric shock.
6. **If operating a power tool in a damp location is unavoidable, use a residual current device (RCD) protected supply.** Use of an RCD reduces the risk of electric shock.
7. **Power tools can produce electromagnetic fields (EMF) that are not harmful to the user.** However, users of pacemakers and other similar medical devices should contact the maker of their device and/or doctor for advice before operating this power tool.

#### Personal safety

1. **Stay alert, watch what you are doing and use common sense when operating a power tool. Do not use a power tool while you are tired or under the influence of drugs, alcohol or medication.** A moment of inattention while operating power tools may result in serious personal injury.
2. **Use personal protective equipment. Always wear eye protection.** Protective equipment such as a dust mask, non-skid safety shoes, hard hat or hearing protection used for appropriate conditions will reduce personal injuries.
3. **Prevent unintentional starting. Ensure the switch is in the off-position before connecting to power source and/or battery pack, picking up or carrying the tool.** Carrying power tools with your finger on the switch or energising power tools that have the switch on invites accidents.
4. **Remove any adjusting key or wrench before turning the power tool on.** A wrench or a key left attached to a rotating part of the power tool may result in personal injury.
5. **Do not overreach. Keep proper footing and balance at all times.** This enables better control of the power tool in unexpected situations.
6. **Dress properly. Do not wear loose clothing or jewellery. Keep your hair and clothing away from moving parts.** Loose clothes, jewellery or long hair can be caught in moving parts.
7. **If devices are provided for the connection of dust extraction and collection facilities, ensure these are connected and properly used.** Use of dust collection can reduce dust-related hazards.
8. **Do not let familiarity gained from frequent use of tools allow you to become complacent and ignore tool safety principles.** A careless action can cause severe injury within a fraction of a second.
9. **Always wear protective goggles to protect your eyes from injury when using power tools. The goggles must comply with ANSI Z87.1 in the USA, EN 166 in Europe, or AS/NZS 1336 in Australia/New Zealand. In Australia/New Zealand, it is legally required to wear a face shield to protect your face, too.**

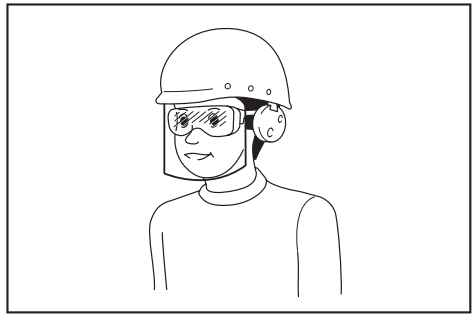

**It is an employer's responsibility to enforce the use of appropriate safety protective equipments by the tool operators and by other persons in the immediate working area.**

#### Power tool use and care

1. **Do not force the power tool. Use the correct power tool for your application.** The correct power tool will do the job better and safer at the rate for which it was designed.
2. **Do not use the power tool if the switch does not turn it on and off.** Any power tool that cannot be controlled with the switch is dangerous and must be repaired.
3. **Disconnect the plug from the power source and/or remove the battery pack, if detachable, from the power tool before making any adjustments, changing accessories, or storing power tools.** Such preventive safety measures reduce the risk of starting the power tool accidentally.
4. **Store idle power tools out of the reach of children and do not allow persons unfamiliar with the power tool or these instructions to operate the power tool.** Power tools are dangerous in the hands of untrained users.
5. **Maintain power tools and accessories. Check for misalignment or binding of moving parts, breakage of parts and any other condition that may affect the power tool's operation. If damaged, have the power tool repaired before use.** Many accidents are caused by poorly maintained power tools.
6. **Keep cutting tools sharp and clean.** Properly maintained cutting tools with sharp cutting edges are less likely to bind and are easier to control.
7. **Use the power tool, accessories and tool bits etc. in accordance with these instructions, taking into account the working conditions and the work to be performed.** Use of the power tool for operations different from those intended could result in a hazardous situation.
8. **Keep handles and grasping surfaces dry, clean and free from oil and grease.** Slippery handles and grasping surfaces do not allow for safe handling and control of the tool in unexpected situations.
9. **When using the tool, do not wear cloth work gloves which may be entangled.** The entanglement of cloth work gloves in the moving parts may result in personal injury.

## Battery tool use and care

1. **Recharge only with the charger specified by the manufacturer.** A charger that is suitable for one type of battery pack may create a risk of fire when used with another battery pack.
2. **Use power tools only with specifically designed battery packs.** Use of any other battery packs may create a risk of injury and fire.
3. **When battery pack is not in use, keep it away from other metal objects, like paper clips, coins, keys, nails, screws or other small metal objects, that can make a connection from one terminal to another.** Shorting the battery terminals together may cause burns or a fire.
4. **Under abusive conditions, liquid may be ejected from the battery; avoid contact. If contact accidentally occurs, flush with water. If liquid contacts eyes, additionally seek medical help.** Liquid ejected from the battery may cause irritation or burns.
5. **Do not use a battery pack or tool that is damaged or modified.** Damaged or modified batteries may exhibit unpredictable behaviour resulting in fire, explosion or risk of injury.
6. **Do not expose a battery pack or tool to fire or excessive temperature.** Exposure to fire or temperature above 130 °C may cause explosion.
7. **Follow all charging instructions and do not charge the battery pack or tool outside the temperature range specified in the instructions.** Charging improperly or at temperatures outside the specified range may damage the battery and increase the risk of fire.

## Service

1. **Have your power tool serviced by a qualified repair person using only identical replacement parts.** This will ensure that the safety of the power tool is maintained.
2. **Never service damaged battery packs.** Service of battery packs should only be performed by the manufacturer or authorized service providers.
3. **Follow instruction for lubricating and changing accessories.**

## Cordless Chain saw safety warnings

1. **Keep all parts of the body away from the saw chain when the chain saw is operating. Before you start the chain saw, make sure the saw chain is not contacting anything.** A moment of inattention while operating chain saws may cause entanglement of your clothing or body with the saw chain.
2. **Always hold the chain saw with your right hand on the top handle and your left hand on the front handle.** Holding the chain saw with a reversed hand configuration increases the risk of personal injury and should never be done.
3. **Hold the power tool by insulated gripping surfaces only, because the saw chain may contact hidden wiring.** Saw chains contacting a "live" wire may make exposed metal parts of the power tool "live" and could give the operator an electric shock.

4. **Wear safety glasses and hearing protection.** Further protective equipment for head, hands, legs and feet is recommended. Adequate protective clothing will reduce personal injury by flying debris or accidental contact with the saw chain.
5. **Always keep proper footing.**
6. **When cutting a limb that is under tension be alert for spring back.** When the tension in the wood fibres is released the spring loaded limb may strike the operator and/or throw the chain saw out of control.
7. **Use extreme caution when cutting brush and saplings.** The slender material may catch the saw chain and be whipped toward you or pull you off balance.
8. **Carry the chain saw by the front handle with the chain saw switched off and away from your body. When transporting or storing the chain saw always fit the guide bar cover.** Proper handling of the chain saw will reduce the likelihood of accidental contact with the moving saw chain.
9. **Follow instructions for lubricating, chain tensioning and changing accessories.** Improperly tensioned or lubricated chain may either break or increase the chance for kickback.
10. **Keep handles dry, clean, and free from oil and grease.** Greasy, oily handles are slippery causing loss of control.
11. **Cut wood only. Do not use chain saw for purposes not intended.** For example: do not use chain saw for cutting plastic, masonry or non-wood building materials. Use of the chain saw for operations different than intended could result in a hazardous situation.
12. **Causes and operator prevention of kickback:** Kickback may occur when the nose or tip of the guide bar touches an object, or when the wood closes in and pinches the saw chain in the cut. Tip contact in some cases may cause a sudden reverse reaction, kicking the guide bar up and back towards the operator. Pinching the saw chain along the top of the guide bar may push the guide bar rapidly back towards the operator. Either of these reactions may cause you to lose control of the saw which could result in serious personal injury. Do not rely exclusively upon the safety devices built into your saw. As a chain saw user, you should take several steps to keep your cutting jobs free from accident or injury. Kickback is the result of tool misuse and/or incorrect operating procedures or conditions and can be avoided by taking proper precautions as given below:
  - Maintain a firm grip, with thumbs and fingers encircling the chain saw handles, with both hands on the saw and position your body and arm to allow you to resist kickback forces. Kickback forces can be controlled by the operator, if proper precautions are taken. Do not let go of the chain saw.

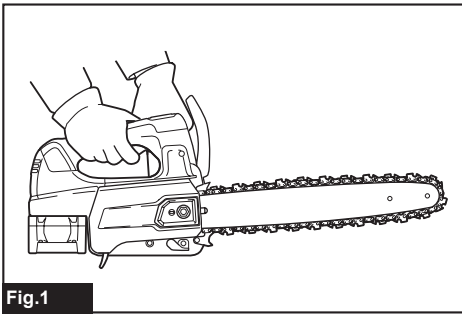

**Fig.1**

- Do not overreach and do not cut above shoulder height. This helps prevent unintended tip contact and enables better control of the chain saw in unexpected situations.
  - Only use replacement bars and chains specified by the manufacturer. Incorrect replacement bars and chains may cause chain breakage and/or kickback.
  - Follow the manufacturer's sharpening and maintenance instructions for the saw chain. Decreasing the depth gauge height can lead to increased kickback.
13. **Before starting work, check that the chain saw is in proper working order and that its condition complies with the safety regulations. Check in particular that:**
- The chain brake is working properly;
  - The run-down brake is working properly;
  - The bar and the sprocket cover are fitted correctly;
  - The chain has been sharpened and tensioned in accordance with the regulations.
14. **Do not start the chain saw with the chain cover being installed on it.** Starting the chain saw with the chain cover being installed on it may cause the chain cover to be thrown out forward resulting in personal injury and damage to objects around the operator.

## Additional Safety Instructions

### Operation

1. **When you use the tool on muddy ground, wet slope, or slippery place, pay attention to your footing.**
2. **Do not submerge the tool into a puddle.**
3. **Do not leave the tool unattended outdoors in the rain.**

### Electrical and battery safety

1. **Avoid dangerous environment. Don't use the tool in dump or wet locations or expose it to rain.** Water entering the tool will increase the risk of electric shock.
2. **Do not dispose of the battery(ies) in a fire.** The cell may explode. Check with local codes for possible special disposal instructions.

3. **Do not open or mutilate the battery(ies).** Released electrolyte is corrosive and may cause damage to the eyes or skin. It may be toxic if swallowed.
4. **Do not charge battery in rain, or in wet locations.**
5. **Do not charge the battery outdoors.**
6. **Do not handle charger, including charger plug, and charger terminals with wet hands.**
7. **Do not replace the battery in the rain.**

### Maintenance and storage

1. **When storing the tool, avoid direct sunlight and rain, and store it in a place where it does not get hot or humid.**

## Top handle chainsaw specific safety warnings

1. **This chain saw is designed especially for tree care and surgery. The chain saw is intended to be used by properly trained persons only. Observe all instructions, procedures and recommendations from the relevant professional organization. Otherwise fatal accidents may occur. It is recommend that always using a rising platform (cherry picker, lift) for sawing in trees. Rappelling techniques are extremely dangerous and require special training. The operators must be trained to become familiar with safety equipment usage and climbing techniques. Always use the appropriate belts, ropes and carabiners when working in trees. Always use restraining equipment for both the operator and the saw.**
2. **Perform cleaning and maintenance before storage in accordance with the instruction manual.**
3. **Ensure safe positioning of the chain saw during car transportation to avoid fuel or chain oil leakage, damage to the tool and personal injury.**
4. **Regularly check the functionality of chain brake.**
5. **Do not fill the chain oil near fire. Never smoke when you fill the chain oil.**
6. **National regulation may restrict the use of the chain saw.**
7. **If the equipment gets heavy impact or fall, check the condition before continuing work. Check the controls and safety devices for malfunction. If there is any damage or doubt, ask our authorized service center for the inspection and repair.**
8. **Always activate the chain brake before starting the chain saw.**
9. **Hold the saw firmly in place to avoid skating (skid movement) or bouncing of the saw when starting a cut.**
10. **At the end of the cut, be careful to keep your balance due to the "drop".**
11. **Take into account the direction and speed of the wind. Avoid sawdust and chain oil mist.**

## Protective equipment

1. **In order to avoid head, eye, hand or foot injuries as well as to protect your hearing the following protective equipment must be used during operation of the chain saw:**
  - The kind of clothing should be appropriate, i. e. it should be tight-fitting but not be a hindrance. Do not wear jewelry or clothing which could become entangled with bushes or shrubs. If you have long hair, always wear a hairnet!
  - It is necessary to wear a protective helmet whenever working with the chain saw. The **protective helmet** is to be checked in regular intervals for damage and is to be replaced after 5 years at the latest. Use only approved protective helmets.
  - The **face shield** of the protective helmet (or the goggles) protects against sawdust and wood chips. During operation of the chain saw always wear a goggle or a face shield to prevent eye injuries.
  - Wear adequate **noise protection equipment** (ear muffs, ear plugs, etc.)
  - The **protective jacket** consists of 22 layers of nylon and protects the operator against cuts. It is always to be worn when working from elevated platforms (cherry pickers, lifts), from platforms mounted on ladders or when climbing with ropes.
  - The **protective brace and bib overall** is made of a nylon fabric with 22 layers and protects against cuts. We strongly recommend its use.
  - **Protective gloves** made of thick leather are part of the prescribed equipment and must always be worn during operation of the chain saw.
  - During operation of the chain saw **safety shoes** or **safety boots** fitted with anti skid sole, steel toe caps and protection for the leg must always be worn. Safety shoes equipped with a protective layer provide protection against cuts and ensure a secure footing. For working in trees the safety boots must be suitable for climbing techniques.

## Vibration

1. Individuals with poor circulation who are exposed to excessive vibration may experience injury to blood vessels or the nervous system. Vibration may cause the following symptoms to occur in the fingers, hands or wrists: "Falling asleep" (numbness), tingling, pain, stabbing sensation, alteration of skin colour or of the skin. **If any of these symptoms occur, see a physician!** To reduce the risk of "white finger disease", keep your hands warm during operation and well maintain the equipment and accessories.

## SAVE THESE INSTRUCTIONS.

**⚠ WARNING: DO NOT** let comfort or familiarity with product (gained from repeated use) replace strict adherence to safety rules for the subject product. **MISUSE** or failure to follow the safety rules stated in this instruction manual may cause serious personal injury.

## Important safety instructions for battery cartridge

1. **Before using battery cartridge, read all instructions and cautionary markings on (1) battery charger, (2) battery, and (3) product using battery.**
2. **Do not disassemble or tamper with the battery cartridge.** It may result in a fire, excessive heat, or explosion.
3. **If operating time has become excessively shorter, stop operating immediately. It may result in a risk of overheating, possible burns and even an explosion.**
4. **If electrolyte gets into your eyes, rinse them out with clear water and seek medical attention right away. It may result in loss of your eyesight.**
5. **Do not short the battery cartridge:**
  - (1) **Do not touch the terminals with any conductive material.**
  - (2) **Avoid storing battery cartridge in a container with other metal objects such as nails, coins, etc.**
  - (3) **Do not expose battery cartridge to water or rain.**

A battery short can cause a large current flow, overheating, possible burns and even a breakdown.
6. **Do not store and use the tool and battery cartridge in locations where the temperature may reach or exceed 50 °C (122 °F).**
7. **Do not incinerate the battery cartridge even if it is severely damaged or is completely worn out. The battery cartridge can explode in a fire.**
8. **Do not nail, cut, crush, throw, drop the battery cartridge, or hit against a hard object to the battery cartridge.** Such conduct may result in a fire, excessive heat, or explosion.
9. **Do not use a damaged battery.**
10. **The contained lithium-ion batteries are subject to the Dangerous Goods Legislation requirements.** For commercial transports e.g. by third parties, forwarding agents, special requirement on packaging and labeling must be observed. For preparation of the item being shipped, consulting an expert for hazardous material is required. Please also observe possibly more detailed national regulations. Tape or mask off open contacts and pack up the battery in such a manner that it cannot move around in the packaging.
11. **When disposing the battery cartridge, remove it from the tool and dispose of it in a safe place. Follow your local regulations relating to disposal of battery.**
12. **Use the batteries only with the products specified by Makita.** Installing the batteries to non-compliant products may result in a fire, excessive heat, explosion, or leak of electrolyte.
13. **If the tool is not used for a long period of time, the battery must be removed from the tool.**
14. **During and after use, the battery cartridge may take on heat which can cause burns or low temperature burns. Pay attention to the handling of hot battery cartridges.**
15. **Do not touch the terminal of the tool immediately after use as it may get hot enough to cause burns.**



16. Do not allow chips, dust, or soil stuck into the terminals, holes, and grooves of the battery cartridge. It may cause heating, catching fire, burst and malfunction of the tool or battery cartridge, resulting in burns or personal injury.
17. Unless the tool supports the use near high-voltage electrical power lines, do not use the battery cartridge near a high-voltage electrical power lines. It may result in a malfunction or breakdown of the tool or battery cartridge.
18. Keep the battery away from children.

## SAVE THESE INSTRUCTIONS.

**CAUTION:** Only use genuine Makita batteries. Use of non-genuine Makita batteries, or batteries that have been altered, may result in the battery bursting causing fires, personal injury and damage. It will also void the Makita warranty for the Makita tool and charger.

## Tips for maintaining maximum battery life

1. Charge the battery cartridge before completely discharged. Always stop tool operation and charge the battery cartridge when you notice less tool power.
2. Never recharge a fully charged battery cartridge. Overcharging shortens the battery service life.
3. Charge the battery cartridge with room temperature at 10 °C - 40 °C (50 °F - 104 °F). Let a hot battery cartridge cool down before charging it.
4. When not using the battery cartridge, remove it from the tool or the charger.
5. Charge the battery cartridge if you do not use it for a long period (more than six months).

## PARTS DESCRIPTION

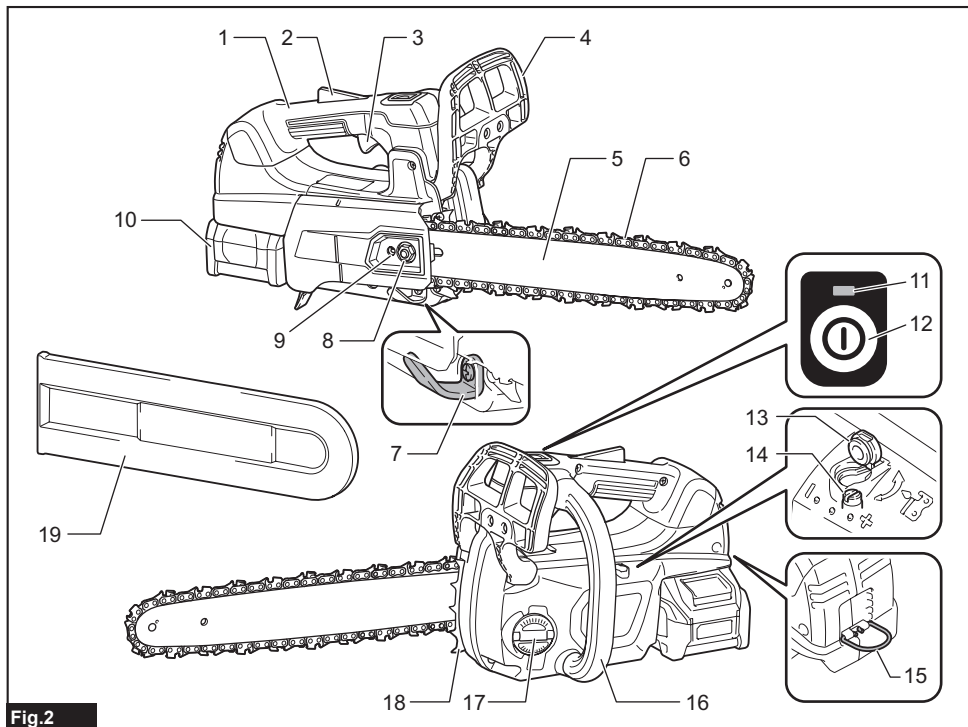

Fig.2

1	Top handle	2	Lock-off lever	3	Switch trigger
4	Front hand guard	5	Guide bar	6	Saw chain
7	Chain catcher	8	Retaining nut	9	Chain adjusting screw
10	Battery cartridge	11	Main power lamp	12	Main power switch
13	Cap	14	Adjusting screw (for oil pump)	15	Carabiner
16	Front handle	17	Oil tank cap	18	Spike bumper
19	Guide bar cover	-	-	-	-

# FUNCTIONAL DESCRIPTION

**CAUTION:** Always be sure that the tool is switched off and the battery cartridge is removed before adjusting or checking function on the tool.

## Installing or removing battery cartridge

**CAUTION:** Always switch off the tool before installing or removing of the battery cartridge.

**CAUTION:** Hold the tool and the battery cartridge firmly when installing or removing battery cartridge. Failure to hold the tool and the battery cartridge firmly may cause them to slip off your hands and result in damage to the tool and battery cartridge and a personal injury.

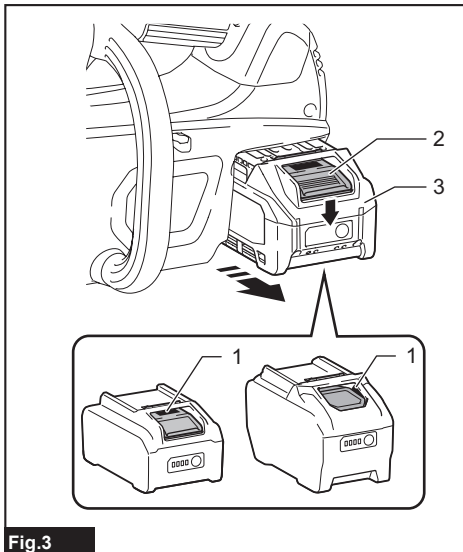

Fig.3

► 1. Red indicator 2. Button 3. Battery cartridge

To remove the battery cartridge, slide it from the tool while sliding the button on the front of the cartridge.

To install the battery cartridge, align the tongue on the battery cartridge with the groove in the housing and slip it into place. Insert it all the way until it locks in place with a little click. If you can see the red indicator as shown in the figure, it is not locked completely.

**CAUTION:** Always install the battery cartridge fully until the red indicator cannot be seen. If not, it may accidentally fall out of the tool, causing injury to you or someone around you.

**CAUTION:** Do not install the battery cartridge forcibly. If the cartridge does not slide in easily, it is not being inserted correctly.

## Indicating the remaining battery capacity

Press the check button on the battery cartridge to indicate the remaining battery capacity. The indicator lamps light up for a few seconds.

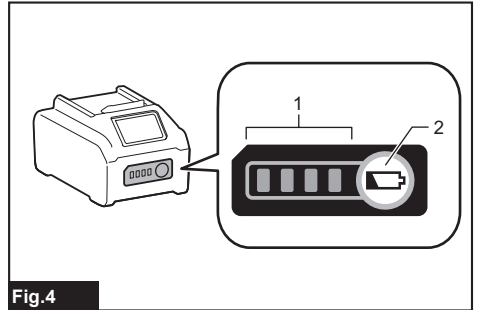

Fig.4

► 1. Indicator lamps 2. Check button

Indicator lamps			Remaining capacity
Lighted	Off	Blinking	
■ ■ ■ ■			75% to 100%
■ ■ ■ □			50% to 75%
■ ■ □ □			25% to 50%
■ □ □ □			0% to 25%
▬ □ □ □			Charge the battery.
■ ■ □ □			The battery may have malfunctioned.
□ □ ■ ■			

**NOTE:** Depending on the conditions of use and the ambient temperature, the indication may differ slightly from the actual capacity.

**NOTE:** The first (far left) indicator lamp will blink when the battery protection system works.

## Tool / battery protection system

The tool is equipped with a tool/battery protection system. This system automatically cuts off power to the motor to extend tool and battery life. The tool will automatically stop during operation if the tool or battery is placed under one of the following conditions:

### Overload protection

When the battery is operated in a manner that causes it to draw an abnormally high current, the tool automatically stops and the main power lamp blinks in green. In this situation, turn the tool off and stop the application that caused the tool to become overloaded. Then turn the tool on to restart.

## Overheat protection

When the tool or battery is overheated, the tool stops automatically and the main power lamp lights up in red. In this case, let the tool and battery cool before turning the tool on again.

**NOTE:** In high temperature environment, the over-heat protection likely to work and the tool stops automatically.

## Overdischarge protection

When the battery capacity is not enough, the tool stops automatically and the main power lamp blinks in red. In this case, remove the battery from the tool and charge the battery.

## Protections against other causes

Protection system is also designed for other causes that could damage the tool and allows the tool to stop automatically. Take all the following steps to clear the causes, when the tool has been brought to a temporary halt or stop in operation.

1. Turn the tool off, and then turn it on again to restart.
2. Charge the battery(ies) or replace it/them with recharged battery(ies).
3. Let the machine and battery(ies) cool down.

If no improvement can be found by restoring protection system, then contact your local Makita Service Center.

**NOTICE:** If the tool stops due to a cause not described above, refer to the section for troubleshooting.

## Main power switch

**WARNING:** Always turn off the main power switch when not in use.

To turn on the tool, press the main power switch. The main power lamp lights up in green. To turn off, press the main power switch again.

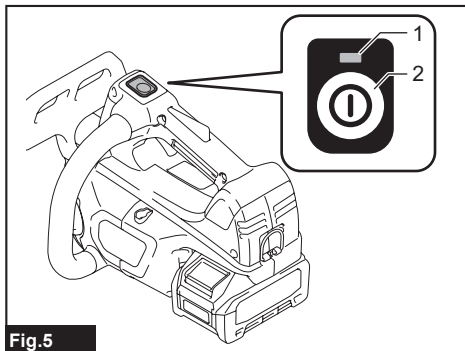

Fig.5

► 1. Main power lamp 2. Main power switch

**NOTE:** The main power lamp blinks in green if the switch trigger is pulled under unoperatable conditions. The lamp blinks in one of the following conditions.

- When you turn on the main power switch while holding down the lock-off lever and the switch trigger.
- When you pull the switch trigger while the chain brake is applied.
- When you release the chain brake while holding down the lock-off lever and pulling the switch trigger.

**NOTE:** This tool employs the auto power-off function. To avoid unintentional start up, the main power switch will automatically shut down when the switch trigger is not pulled for a certain period after the main power switch is turned on.

## Switch action

**WARNING:** For your safety, this tool is equipped with lock-off lever which prevents the tool from unintended starting. NEVER use the tool if it runs when you simply pull the switch trigger without pressing the lock-off lever. Return the tool to our authorized service center for proper repairs BEFORE further usage.

**WARNING:** NEVER tape down or defeat purpose and function of lock-off lever.

**CAUTION:** Before installing the battery cartridge into the tool, always check to see that the switch trigger actuates properly and returns to the "OFF" position when released.

**NOTICE:** Do not pull the switch trigger hard without pressing the lock-off lever. This can cause switch breakage.

**NOTE:** When you keep pulling the switch trigger while the tool is under almost no load, the rotation speed of the tool decreases and the main power lamp blinks in green. In this case, release the switch trigger, and then pull the switch trigger again.

To prevent the switch trigger from being accidentally pulled, a lock-off lever is provided. To start the tool, depress the lock-off lever and pull the switch trigger. The tool speed increases by increasing pressure on the switch trigger. Release the switch trigger to stop.

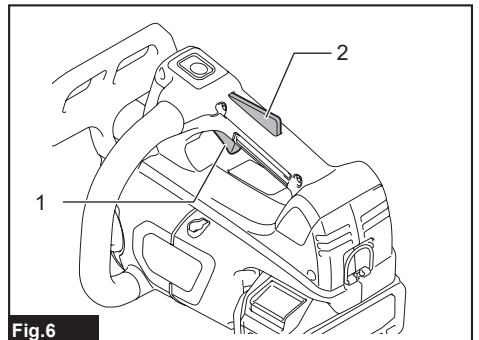

Fig.6

► 1. Switch trigger 2. Lock-off lever

## Checking the chain brake

**CAUTION:** Hold the chain saw with both hands when switching it on. Hold the top handle with your right hand, the front handle with your left. The guide bar and the saw chain must not be in contact with any object.

**CAUTION:** Should the saw chain not stop immediately when this test is performed, the chain saw may not be used under any circumstances. Consult our authorized service center.

1. Press the lock-off lever, then pull the switch trigger. The saw chain starts immediately.
2. Push the front hand guard forwards with the back of your hand. Make sure that the chain saw comes to an immediate standstill.

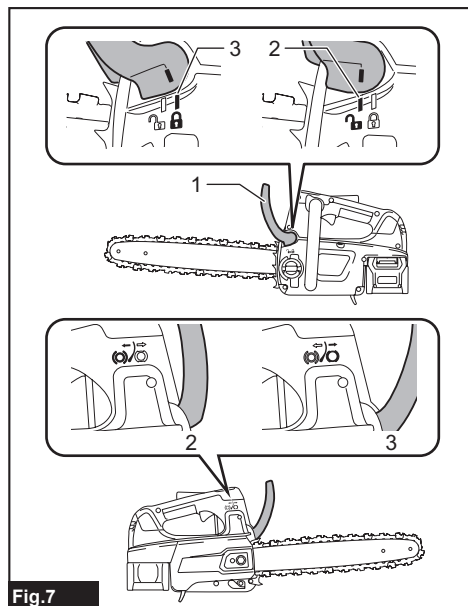

- 1. Front hand guard 2. Unlocked position 3. Locked position

## Checking the run-down brake

**CAUTION:** If the saw chain does not stop within two seconds in this test, stop using the chain saw and consult our authorized service center.

Run the chain saw then release the switch trigger completely. The saw chain must come to a standstill within two seconds.

## Adjusting the chain lubrication

You can adjust the oil pump feed rate with the adjusting screw using the universal wrench. The amount of oil can be adjusted in 3 steps. Open the cap to adjust the adjusting screw.

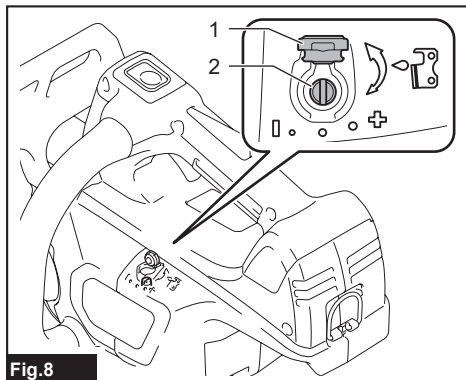

- 1. Cap 2. Adjusting screw

## Carabiner (rope attachment point)

You can hang the tool by attaching the rope to the carabiner. Pull up the carabiner, and then tie it with the rope.

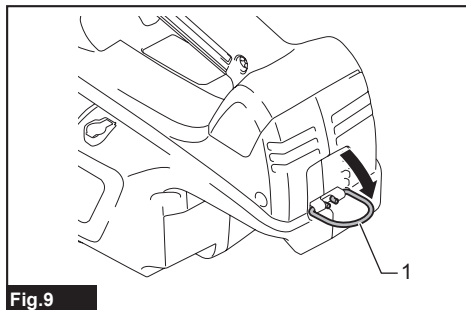

- 1. Carabiner

## Spike bumper

The tool is equipped with the spike bumper as standard. For replacement of the spike bumper, ask Makita Authorized Service Centers.

When you perform the cutting operation, engage the spike bumper with the trunk and use it as a lever.

## Electronic function

The tool is equipped with the electronic functions for easy operation.

- Electric brake  
This tool is equipped with an electric brake. If the tool consistently fails to quickly stop after the switch trigger is released, have the tool serviced at a Makita service center.

# ASSEMBLY

**⚠ CAUTION:** Always be sure that the tool is switched off and the battery cartridge is removed before carrying out any work on the tool.

**⚠ CAUTION:** Do not touch the saw chain with bare hands. Always wear gloves when handling the saw chain.

## Installing or removing saw chain

**⚠ CAUTION:** The saw chain and the guide bar are still hot just after the operation. Let them cool down enough before carrying out any work on the tool.

**⚠ CAUTION:** Carry out the procedure of installing or removing saw chain in a clean place free from sawdust and the like.

## Installing the saw chain

To install the saw chain, perform the following steps:

1. Release the chain brake by pulling the front hand guard.
2. Loosen the chain adjusting screw, then the retaining nut.

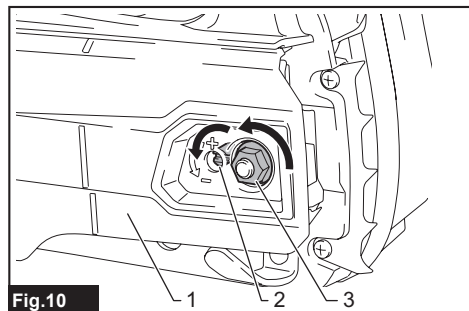

Fig.10

► 1. Sprocket cover 2. Chain adjusting screw 3. Retaining nut

3. Remove the sprocket cover.
4. Check the direction of the saw chain. Match the direction of the saw chain with that of the mark on the chain saw body.

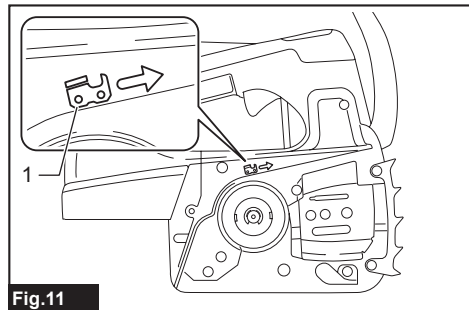

Fig.11

► 1. Mark on chain saw body

5. Fit one end of the saw chain on the top of the guide bar.

6. Fit the other end of the saw chain around the sprocket, then attach the guide bar to the chain saw body, aligning the hole on the guide bar with the pin on the chain saw body.

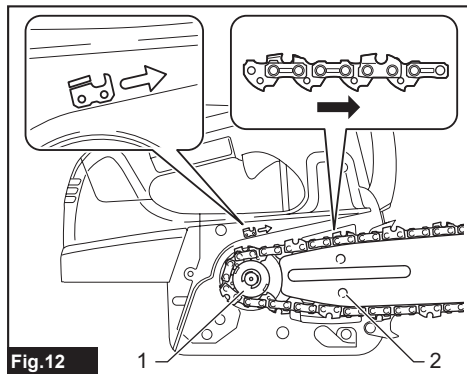

Fig.12

► 1. Sprocket 2. Hole

7. Insert the protrusion and the pin on the sprocket cover to the chain saw body, and then close the cover so that the bolt and pin on the chain saw body meet their counterparts on the cover.

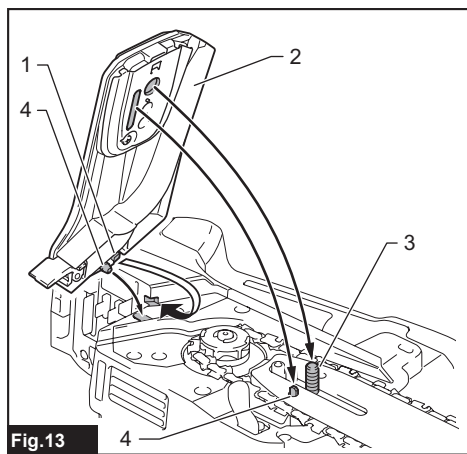

Fig.13

► 1. Protrusion 2. Sprocket cover 3. Bolt 4. Pin

8. Tighten the retaining nut to secure the sprocket cover, then loosen it a bit for tension adjustment.

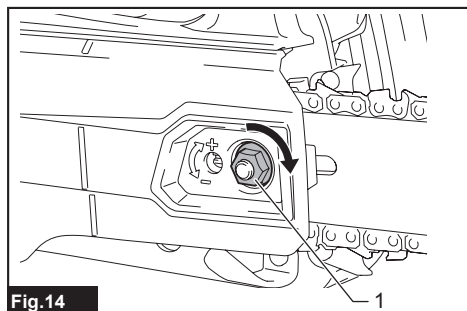

Fig.14

► 1. Retaining nut

After installing the saw chain, adjust the saw chain tension by referring to the section for adjusting saw chain tension.

## Removing the saw chain

To remove the saw chain, perform the following steps:

1. Release the chain brake by pulling the front hand guard.
2. Loosen the chain adjusting screw, then the retaining nut.

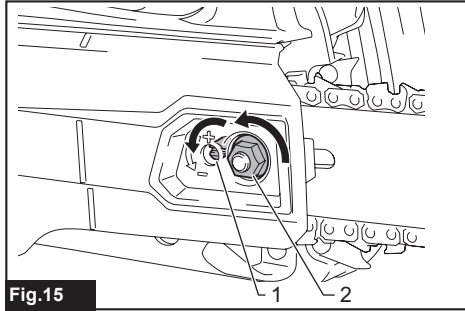

Fig.15

- 1. Chain adjusting screw 2. Retaining nut

3. Remove the sprocket cover then remove the saw chain and guide bar from the chain saw body.

## Adjusting saw chain tension

**CAUTION:** Do not tighten the saw chain too much. Excessively high tension of saw chain may cause breakage of saw chain and wear of the guide bar.

**CAUTION:** A chain which is too loose can jump off the bar and it may cause an injury accident.

The saw chain may become loose after many hours of use. From time to time check the saw chain tension before use.

1. Release the chain brake by pulling the front hand guard.
2. Loosen the retaining nut a bit to loosen the sprocket cover lightly.

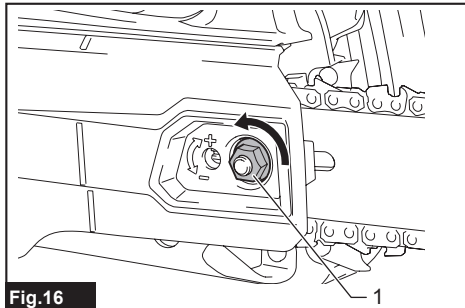

Fig.16

- 1. Retaining nut

3. Lift up the guide bar tip slightly and adjust the chain tension. Turn the chain adjusting screw clockwise to tighten, turn it counterclockwise to loosen.

### For chain blade 90PX and 91PX:

Tighten the saw chain until the lower side of the saw chain fits in the guide bar rail as illustrated.

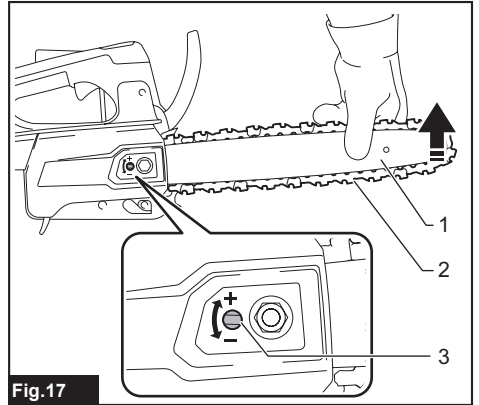

Fig.17

- 1. Guide bar 2. Saw chain 3. Chain adjusting screw

### For chain blade 25AP:

Tighten the saw chain so that the gap between the center of the lower side of the guide bar and the saw chain becomes approximately 1 mm to 2 mm.

4. Keep holding the guide bar lightly and tighten the sprocket cover.

### For chain blade 90PX and 91PX:

Make sure that the saw chain does not loose at the lower side.

### For chain blade 25AP:

Make sure that the gap between the center of the lower side of the guide bar and the saw chain is approximately 1 mm to 2 mm.

5. Tighten the retaining nut to secure the sprocket cover.

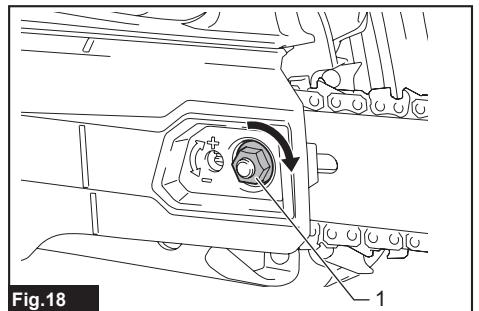

Fig.18

- 1. Retaining nut

# OPERATION

## Lubrication

**NOTICE:** When filling the chain oil for the first time, or refilling the tank after it has been completely emptied, add oil up to the bottom edge of the filler neck. The oil delivery may otherwise be impaired.

**NOTICE:** Use the saw chain oil exclusively for Makita chain saws or equivalent oil available in the market.

**NOTICE:** Never use oil including dust and particles or volatile oil.

**NOTICE:** When pruning trees, use botanical oil. Mineral oil may harm trees.

**NOTICE:** Before the cutting operation, make sure that the provided oil tank cap is screwed in place.

Saw chain is automatically lubricated when the tool is in operation. Check the amount of remaining oil in the oil tank periodically through the oil inspection window.

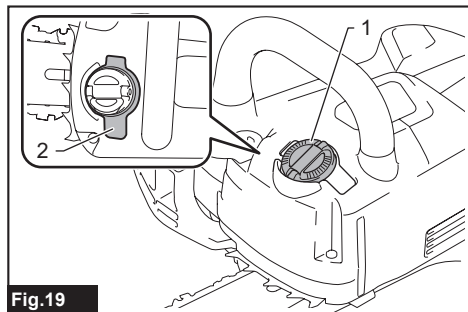

Fig.19

► 1. Oil tank cap 2. Oil inspection window

To refill the tank, lay the chain saw on its side, then push the button on the oil tank cap so that the button on the other side stands up, and then remove the oil tank cap by turning it. The proper amount of oil is 200 ml. After refilling the tank, make sure that the oil tank cap is tightened securely.

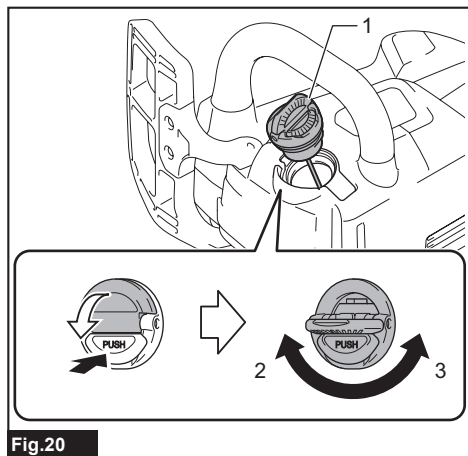

Fig.20

► 1. Oil tank cap 2. Tighten 3. Loosen

**NOTE:** If it is difficult to remove the oil tank cap, insert the box wrench into the slot of the oil tank cap, and then remove the oil tank cap by turning it counterclockwise.

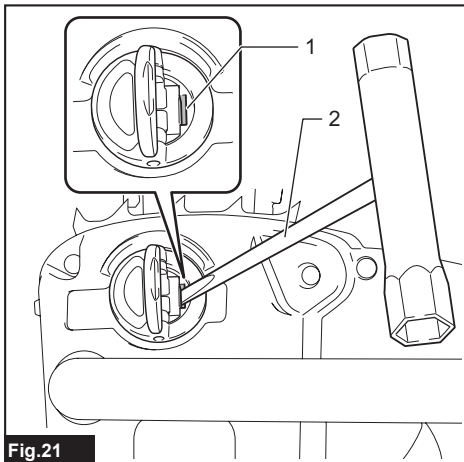

Fig.21

► 1. Slot 2. Box wrench

After refilling, hold the chain saw away from the tree. Start it and wait until lubrication on saw chain is adequate.

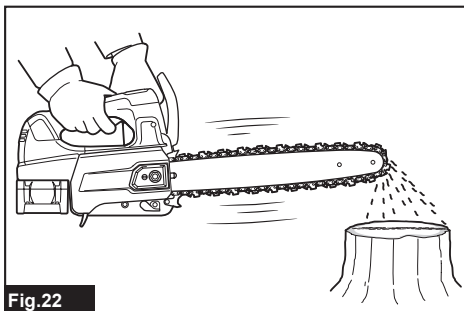

Fig.22

## Working with the chain saw

**CAUTION:** Keep all parts of the body away from the saw chain when the motor is operating.

**CAUTION:** Hold the chain saw firmly with both hands when the motor is running.

**CAUTION:** Do not overreach. Keep proper footing and balance at all times.

**NOTICE:** Never toss or drop the tool.

**NOTICE:** Do not cover the vents of the tool.

## Pruning trees

Bring the chain saw body into contact with the branch to be cut before switching on. Otherwise it may cause the guide bar to wobble, resulting in injury to operator. Saw the wood to be cut by just moving it down by using the weight of the chain saw.

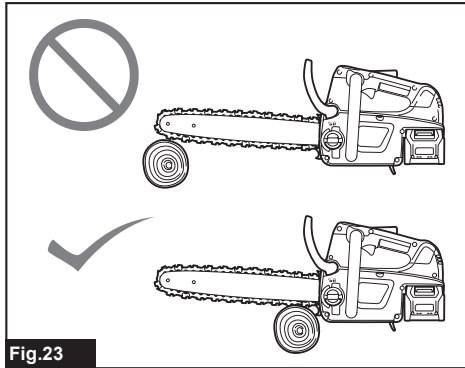

Fig.23

If you cannot cut the timber right through with a single stroke:  
Apply light pressure to the handle and continue sawing and draw the chain saw back a little.

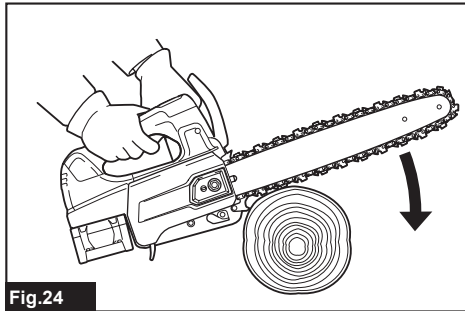

Fig.24

When cutting thick branches, first make a shallow undercut and then make the finish cut from the top.

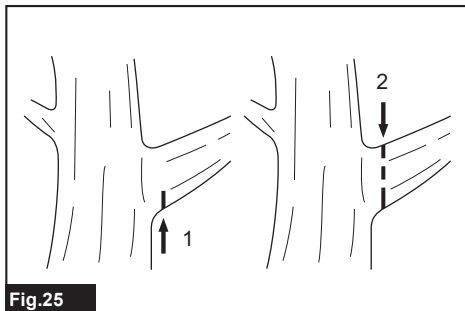

Fig.25

If you try to cut off thick branches from the bottom, the branch may close in and pinch the saw chain in the cut. If you try to cut off thick branches from the top without a shallow undercut, the branch may splinter.

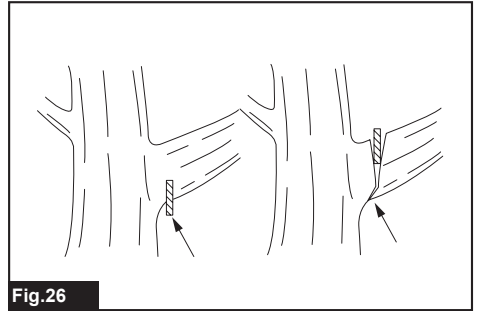

Fig.26

## Carrying tool

Before carrying the tool, always apply the chain brake and remove the battery cartridge from the tool. Then attach the guide bar cover. Also cover the battery cartridge with the battery cover.

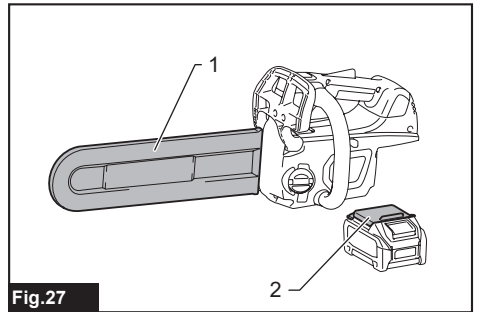

Fig.27

► 1. Guide bar cover 2. Battery cover

## MAINTENANCE

**CAUTION:** Always be sure that the tool is switched off and the battery cartridge is removed before attempting to perform inspection or maintenance.

**CAUTION:** Always wear gloves when performing any inspection or maintenance.

**NOTICE:** Never use gasoline, benzene, thinner, alcohol or the like. Discoloration, deformation or cracks may result.

To maintain product SAFETY and RELIABILITY, repairs, any other maintenance or adjustment should be performed by Makita Authorized or Factory Service Centers, always using Makita replacement parts.



## Sharpening the saw chain

### Sharpen the saw chain when:

- Mealy sawdust is produced when damp wood is cut;
- The chain penetrates the wood with difficulty, even when heavy pressure is applied;
- The cutting edge is obviously damaged;
- The saw pulls to the left or right in the wood. (caused by uneven sharpening of the saw chain or damage to one side only)

Sharpen the saw chain frequently but a little each time. Two or three strokes with a file are usually sufficient for routine resharpening. When the saw chain has been resharpened several times, have it sharpened in our authorized service center.

### Sharpening criteria:

**⚠ WARNING: An excessive distance between the cutting edge and depth gauge increases the risk of kickback.**

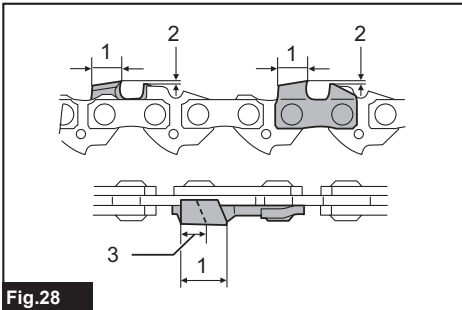

Fig.28

- 1. Cutter length 2. Distance between cutting edge and depth gauge 3. Minimum cutter length (3 mm)
- All cutter length must be equal. Different cutter lengths prevent the saw chain from running smoothly and may cause the saw chain to break.
  - Do not sharpen the chain when the cutter length has reached 3 mm or shorter. The chain must be replaced with new one.
  - The chip thickness is determined by the distance between the depth gauge (round nose) and the cutting edge.
  - The best cutting results are obtained with following distance between cutting edge and depth gauge.
    - Chain blade 90PX : 0.65 mm
    - Chain blade 91PX : 0.65 mm
    - Chain blade 25AP : 0.65 mm

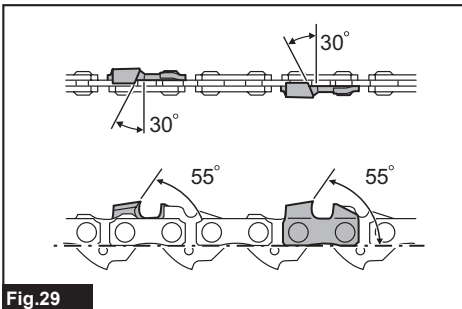

Fig.29

- The sharpening angle of 30° must be the same on all cutters. Different cutter angles cause the chain to run roughly and unevenly, accelerate wear, and lead to chain breaks.
- Use a suitable round file so that the proper sharpening angle is kept against the teeth.
  - Chain blade 90PX : 55°
  - Chain blade 91PX : 55°
  - Chain blade 25AP : 55°

### File and file guiding

- Use a special round file (optional accessory) for saw chains to sharpen the chain. Normal round files are not suitable.
- Diameter of the round file for each saw chain is as follows:
  - Chain blade 90PX : 4.5 mm
  - Chain blade 91PX : 4.0 mm
  - Chain blade 25AP : 4.0 mm
- The file should only engage the cutter on the forward stroke. Lift the file off the cutter on the return stroke.
- Sharpen the shortest cutter first. Then the length of this shortest cutter becomes the standard for all other cutters on the saw chain.
- Guide the file as shown in the figure.

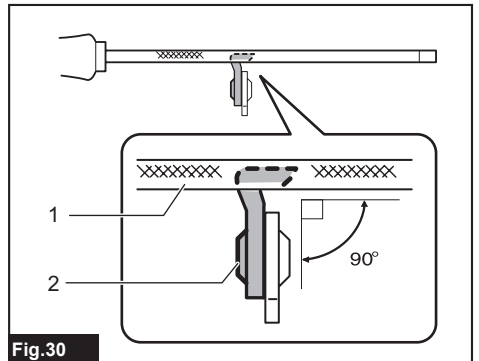

Fig.30

- 1. File 2. Saw chain
- The file can be guided more easily if a file holder (optional accessory) is employed. The file holder has markings for the correct sharpening angle of 30° (align the markings parallel to the saw chain) and limits the depth of penetration (to 4/5 of the file diameter).

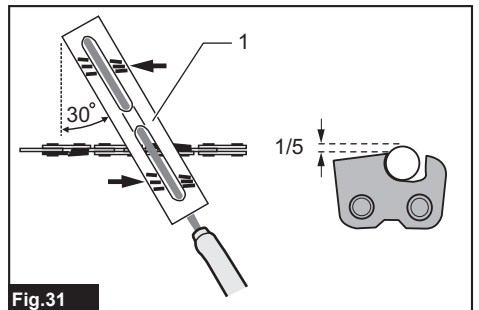

Fig.31

- 1. File holder

- After sharpening the chain, check the height of the depth gauge using the chain gauge tool (optional accessory).

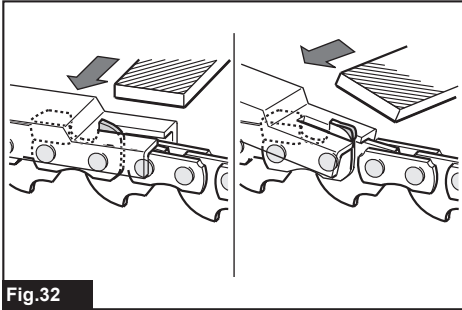

Fig.32

- Remove any projecting material, however small, with a special flat file (optional accessory).
- Round off the front of the depth gauge again.

### Cleaning the guide bar

Chips and sawdust will build up in the guide bar groove. They may clog the bar groove and impair the oil flow. Clean out the chips and sawdust every time when you sharpen or replace the saw chain.

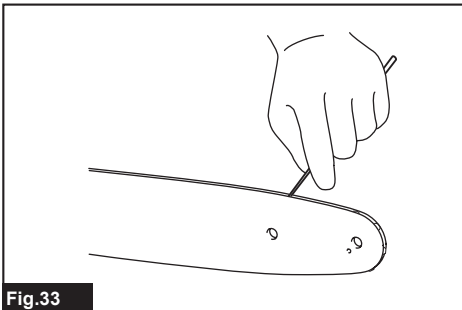

Fig.33

### Cleaning the sprocket cover

Chips and saw dust will accumulate inside of the sprocket cover. Remove the sprocket cover and saw chain from the tool then clean the chips and saw dust.

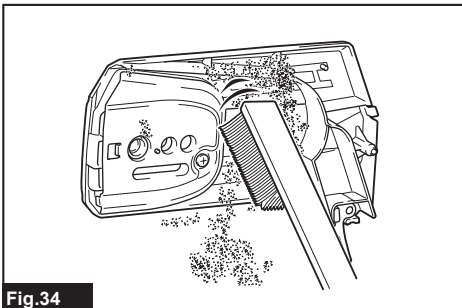

Fig.34

### Cleaning the oil discharge hole

Small dust or particles may be built up in the oil discharge hole during operation. These dust or particles may impair the oil to flow and cause an insufficient lubrication on the whole saw chain. When a poor chain oil delivery occurs at the top of guide bar, clean the oil discharge hole as follows.

1. Remove the sprocket cover and saw chain from the tool.
2. Remove the small dust or particles using a slotted screwdriver or the like.

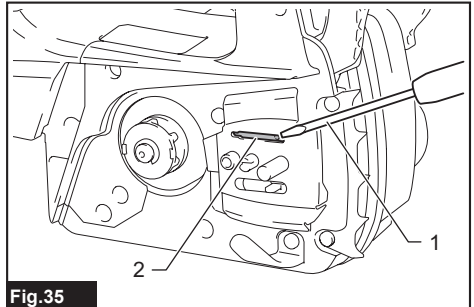

Fig.35

- 1. Slotted screwdriver 2. Oil discharge hole

3. Insert the battery cartridge into the tool. Pull the switch trigger to flow built-up dust or particles off the oil discharge hole by discharging chain oil.
4. Remove the battery cartridge from the tool. Reinstall the sprocket cover and saw chain on the tool.

### Replacing the sprocket

**CAUTION:** A worn sprocket will damage a new saw chain. Have the sprocket replaced in this case.

Before fitting a new saw chain, check the condition of the sprocket.

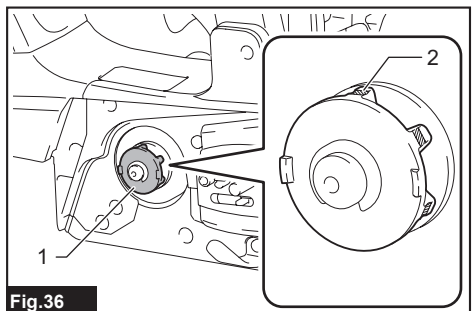

Fig.36

- 1. Sprocket 2. Areas to be worn out

Always fit a new locking ring when replacing the sprocket.

## Storing the tool

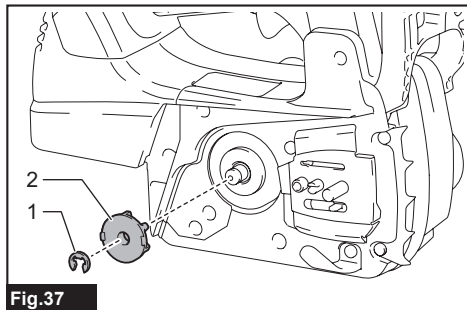

Fig.37

► 1. Locking ring 2. Sprocket

1. Clean the tool before storing. Remove any chips and sawdust from the tool after removing the sprocket cover.
2. After cleaning the tool, run it under no load to lubricate the saw chain and guide bar.
3. Cover the guide bar with the guide bar cover.
4. Empty the oil tank.

**NOTICE:** Make sure that the sprocket is installed as shown in the figure.

## Instructions for periodic maintenance

To ensure long life, prevent damage and ensure the full functioning of the safety features, the following maintenance must be performed regularly. Warranty claims can be recognized only if this work is performed regularly and properly. Failure to perform the prescribed maintenance work can lead to accidents! The user of the chain saw must not perform maintenance work which is not described in the instruction manual. All such work must be carried out by our authorized service center.

Check item / Operating time		Before operation	Everyday	Every week	Every 3 month	Annually	Before storage
Chain saw	Inspection.	✓	-	-	-	-	-
	Cleaning.	-	✓	-	-	-	-
	Check at authorized service center.	-	-	-	-	✓	✓
Saw chain	Inspection.	✓	-	-	-	-	-
	Sharpening if necessary.	-	-	-	-	-	✓
Guide bar	Inspection.	✓	✓	-	-	-	-
	Remove from the chain saw.	-	-	-	-	-	✓
Chain brake	Check the function.	✓	-	-	-	-	-
	Have it inspected regularly at authorized service center.	-	-	-	✓	-	-
Chain lubrication	Check the oil feed rate.	✓	-	-	-	-	-
Switch trigger	Inspection.	✓	-	-	-	-	-
Lock-off lever	Inspection.	✓	-	-	-	-	-
Oil tank cap	Check tightness.	✓	-	-	-	-	-
Chain catcher	Inspection.	-	-	✓	-	-	-
Screws and nuts	Inspection.	-	-	✓	-	-	-

# TROUBLESHOOTING

Before asking for repairs, conduct your own inspection first. If you find a problem that is not explained in the manual, do not attempt to dismantle the tool. Instead, ask Makita Authorized Service Centers, always using Makita replacement parts for repairs.

Malfunction status	Cause	Action
The chain saw does not start.	Battery cartridge is not installed.	Install a charged battery cartridge.
	Battery problem (low voltage).	Recharge the battery cartridge. If recharging is not effective, replace the battery cartridge.
	Main power switch is off.	The chain saw is automatically turned off if it is un-operated for a certain period. Turn on the main power switch again.
The saw chain does not run.	Chain brake activated.	Release chain brake.
The motor stops running after a little use.	Battery's charge level is low.	Recharge the battery cartridge. If recharging is not effective, replace the battery cartridge.
No oil on the chain.	Oil tank is empty.	Fill the oil tank.
	Oil guide groove is dirty.	Clean the groove.
	Poor oil delivery.	Adjust the amount of oil delivery with the adjusting screw.
The chain saw does not reach maximum RPM.	Battery cartridge is installed improperly.	Install the battery cartridge as described in this manual.
	Battery power is dropping.	Recharge the battery cartridge. If recharging is not effective, replace the battery cartridge.
	The drive system does not work correctly.	Ask the authorized service center in your region for repair.
The main power lamp is blinking in green.	Switch trigger is pulled under an unoperable condition.	Pull the switch trigger after the main power switch is turned on and the chain brake is released.
Chain does not stop even the chain brake is activated: <b>Stop the tool immediately!</b>	The brake band is worn down.	Ask the authorized service center in your region for repair.
Abnormal vibration: <b>Stop the tool immediately!</b>	Loose guide bar or saw chain.	Adjust the guide bar and saw chain tension.
	Tool malfunction.	Ask the authorized service center in your region for repair.
The saw chain cannot be installed.	The combination of saw chain and sprocket is not correct.	Use the correct combination of saw chain and sprocket by referring to the section for specifications.

# OPTIONAL ACCESSORIES

**⚠ CAUTION:** These accessories or attachments are recommended for use with your Makita tool specified in this manual. The use of any other accessories or attachments might present a risk of injury to persons. Only use accessory or attachment for its stated purpose.

If you need any assistance for more details regarding these accessories, ask your local Makita Service Center.

- Saw chain
- Guide bar
- Guide bar cover
- Sprocket
- File
- Makita genuine battery and charger

**⚠ WARNING:** If you purchase a guide bar of different length from the standard guide bar, also purchase a suitable guide bar cover together. It must fit and fully cover the guide bar on the chain saw.

**NOTE:** Some items in the list may be included in the tool package as standard accessories. They may differ from country to country.





**Makita Europe N.V.** Jan-Baptist Vinkstraat 2,  
3070 Kortenberg, Belgium

**Makita Corporation** 3-11-8, Sumiyoshi-cho,  
Anjo, Aichi 446-8502 Japan

[www.makita.com](http://www.makita.com)

885906-227 EN 20211209
------------------------------