

# Model No.HM1501 ELECTRIC BREAKER

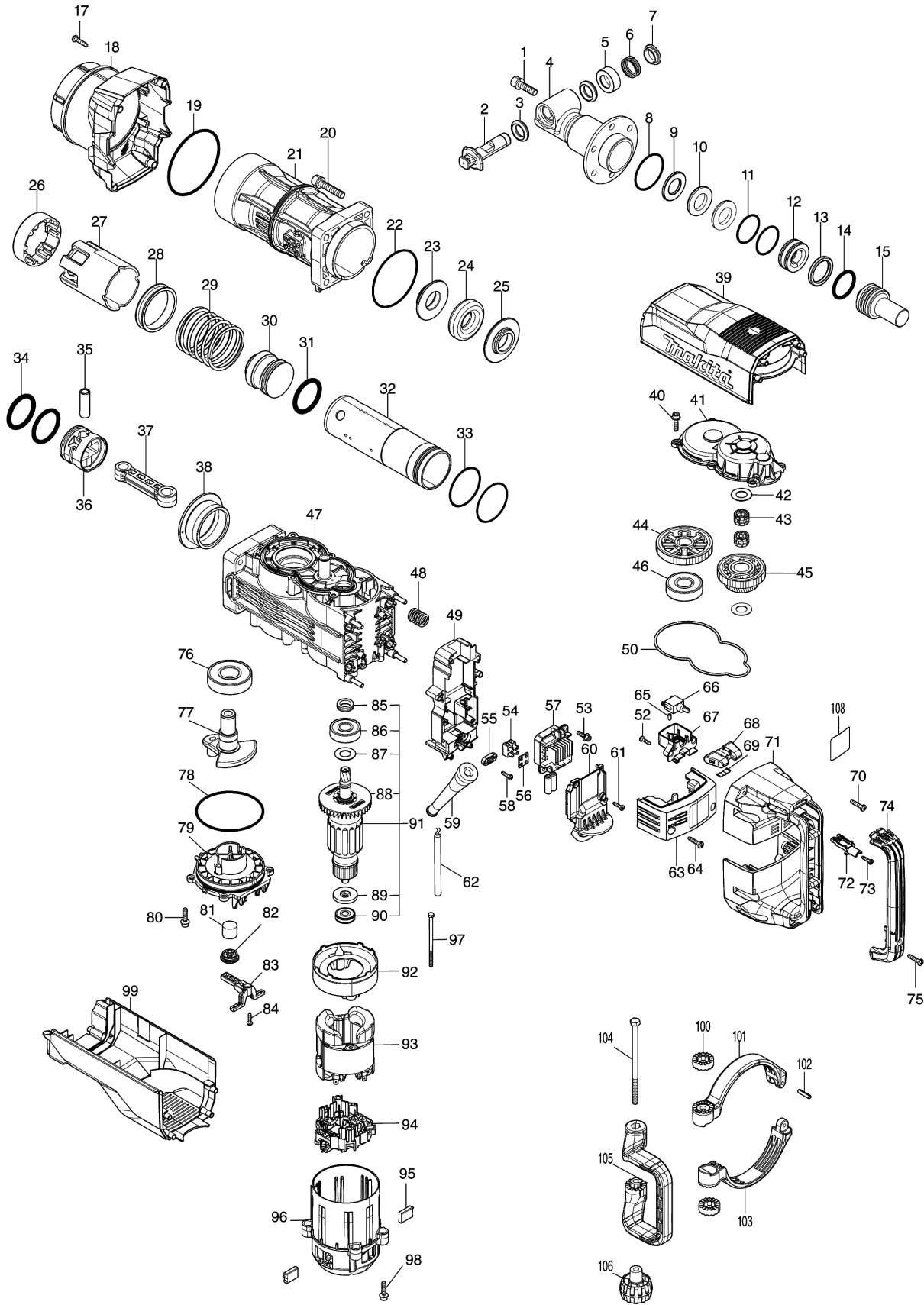



Model No.HM1501 ELECTRIC BREAKER

Item	Parts No.	Description	I/C	Qty	New/Old	Opt. 1	Opt. 2	Note
001	265B53-0	H.S HEAD BOLT M10X35 WM		6				
002	327671-1	TOOL RETAINER		1				
003	262197-5	RUBBER RING 20		2				
004	313322-2	TOOL HOLDER A		1				
005	327672-9	SPRING BASE B		1				
006	232641-6	COMPRESSION SPRING 28		1				
007	327670-3	RETAINER SLEEVE		1				
008	213670-8	O RING 58		1				
009	253487-7	FLAT WASHER 26		1				
010	262198-3	URETHANE RING 26		2	*			
010-1	262198-3	URETHANE RING 26	<	2				
011	213569-7	O形圈45 - HM1317C		2				
012	327674-5	RING 24		1				
013	213911-2	X-RING 38		1				
014	213912-0	O-RING 40		1				
015	327668-0	IMPACT BOLT A		1				
017	266041-8	自更螺絲PT5X25 5277NB		4				
018	412874-1	BARREL COVER		1				
019	213916-2	O-RING106		1				
020	265B55-6	H.S HEAD BOLT M10X50 WM		4				
021	313324-8	BARREL		1				
022	213806-9	O形圈90 - HR2500		1				
023	327667-2	SHOULDER RING 30 B		1				
024	262196-7	RUBBER RING 31		1				
025	327666-4	SHOULDER RING 30 A		1				
026	313321-4	GUIDE RING		1				
027	412859-7	SLIDE SLEEVE		1				
028	327664-8	SLEEVE 65		1				
029	232646-6	COMPRESSION SPRING 66		1				
030	327665-6	STRIKER		1				
031	213913-8	O-RING 48		1				
032	327662-2	CYLINDER 59		1				
033	213656-2	O形圈53 - HM1201		2				
034	213913-8	O-RING 48		2				
035	327663-0	PIPE 15		1				
036	412858-9	PISTON		1				
037	412857-1	CONNECTING ROD		1				
038	327661-4	SPACER		1				
039	412875-9	TOP COVER		1				
040	266923-4	內六角圓柱頭螺柱M6X25 GM		6				

Please order the parts with part number.

Print Date 8/6/2021

Model No.HM1501 ELECTRIC BREAKER

Item	Parts No.	Description	I/C	Qty	New/Old	Opt. 1	Opt. 2	Note
041	413211-2	GEAR COVER		1				
042	267487-1	FLAT WASHER 17		2				
043	212230-3	NEEDLE CAGE 1715		2				
044	227832-2	HELICAL GEAR 53		1				
045	227833-0	GEAR COMPLETE 31-45		1				
046	210234-9	BALL BEARING 2216LLB		1				
047	140W39-0	CRANK HOUSING B COMPLETE		1				
048	232645-8	COMPRESSION SPRING 16B		4				
049	412868-6	CONTROLLER CASE		1				
050	422636-9	SEAL RING		1				
052	265995-6	自攻螺釘4X18		2				
053	266903-0	HEX.S.HEAD BOLT M5X20 WITH WR		2				
054	654741-6	TERMINAL BLOCK		2				
055	687053-2	軟線壓板 - 2414B		1				
056	685756-2	膠墊 - HM1812		2				
057Y	620E04-2	CONTROLLER		1				
057Z	620E00-0	CONTROLLER		1				
058	265995-6	自攻螺釘4X18		2				
059	682560-0	軟線護套10 - HM1304		1				
060	412869-4	CORD COVER		1				
061	265995-6	自攻螺釘4X18		4				
062Y	692637-3	POWER SUPPLY CORD 1.5- 2-5.0		1				
062Z	695237-8	POWER SUPPLY CORD 1.5- 2-5.0		1				
063	140W49-7	CONTROLLER COVER COMPLETE		1				
064	266041-8	自更螺絲PT5X25 5277NB		2				
065	263027-3	RUBBER PIN 4		1				
066	651423-1	開關 - HM1317C		1				
067	412878-3	SWITCH HOLDER		1				
068	451112-6	SLIDE LEVER		1				
069	232209-8	LEAF SPRING		1				
070	266041-8	自更螺絲PT5X25 5277NB		8				
071	140W50-2	HANDLE COMPLETE		1				
C10	263044-3	RUBBER PIN 6		4				
072	412879-1	SWITCH SUPPORT		1				
073	265995-6	自攻螺釘4X18		1				
074	412880-6	HANDLE COVER		1				
075	266041-8	自更螺絲PT5X25 5277NB		1				

Model No.HM1501 ELECTRIC BREAKER

Item	Parts No.	Description	I/C	Qty	New/Old	Opt. 1	Opt. 2	Note
076	210233-1	BALL BEARING 2818LLU		1				
077	327660-6	CRANK SHAFT		1				
078	213914-6	O-RING 100		1				
079	412864-4	CRANK CAP B		1				
080	266923-4	內六角圓柱頭螺栓M6X25 GM		4				
081	443127-7	過濾器 - HM1317C		1				
082	424668-2	過濾器蓋 - HM1812		1				
083	412867-8	FILTER GUIDE		1				
084	265995-6	自攻螺釘4X18		1				
085	332129-7	SEALING SCREW		1				
086	211152-4	BALL BEARING 6303LLU		1				
087	267487-1	FLAT WASHER 17		1				
088	240213-3	FAN 80		1				
089	681630-2	絕緣墊圈 - 9069		1				
090	210232-3	BALL BEARING 6200DDW		1				
091Y	515543-4	ARMATURE ASSY 220V		1				
091Z	515541-8	ARMATURE ASSY 115V		1				
D10		INC. 85-90						
092	412861-0	BUFFLE PLATE		1				
093Y	634748-8	FIELD 220V		1				
093Z	634746-2	FIELD 115V		1				
094	632R65-8	BRUSH HOLDER UNIT		1				
095	197129-2	碳刷CB-218 - HM1812		1				
096	412860-2	MOTOR HOUSING		1				
097	265B54-8	+ HEX BOLT M5X95 WITH GM		2				
098	266923-4	內六角圓柱頭螺栓M6X25 GM		4				
099	412886-4	REAR COVER B		1				
100	417002-3	SIDE HANDLE CAM		2				
101	312A28-5	SIDE HANDLE BASE A		1				
102	951166-8	彈性圓柱銷5-24 - LC1210		1				
103	312A29-3	SIDE HANDLE BASE B		1				
104	265439-6	HEX. BOLT M8X150		1				
105	412881-4	SIDE HANDLE		1				
106	252640-2	WING NUT M8		1				
108	858C25-4	HM1501 NAME PLATE		1				
A01	D-15285	尖鑿400		1				
A02	821839-6	PLASTIC CARRYING CASE		1				
A03Y	8028F6-2	HM1501 PLASTIC CASE LABEL		2				
A03Z	8028F6-2	HM1501 PLASTIC CASE LABEL		2	*			

Model No.HM1501 ELECTRIC BREAKER

Item	Parts No.	Description	I/C	Qty	New/Old	Opt. 1	Opt. 2	Note
A03-1Z	8036K6-8	HM1501 PLASTIC CASE LABEL	<	2				
E01	8027J9-8	SOUND XXDB LABEL		1	*			
E01-1	801095-4	SOUND 106DB LABEL	<	1				
E02Z	655030-2	PLUG UK TYPE 16A-4H/110V		1				
E03Z	654091-9	NON-INSULATED TERMINAL1.25-2AF		2				

Please order the parts with part number.

Print Date 8/6/2021