

INSTRUCTION MANUAL

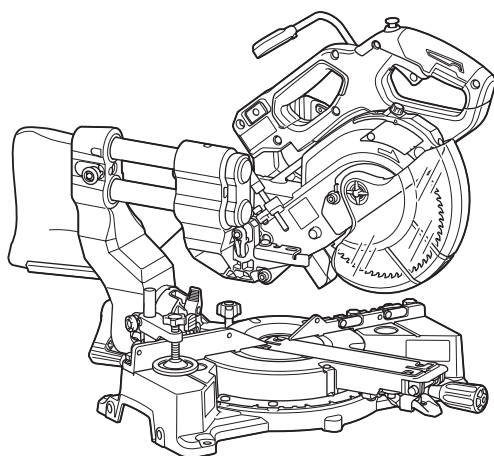

Cordless Slide Compound Miter Saw

DLS610



Read before use.

SPECIFICATIONS

Model:	DLS610
Blade diameter	165 mm
Hole (arbor) diameter (country specific)	20 mm
Max. kerf thickness of the saw blade	1.9 mm
Max. miter angle	Left 47°, Right 57°
Max. bevel angle	Left 46°, Right 46°
No load speed	5,000 min ⁻¹
Laser type	Red Laser 650 nm, Maximum output < 1.6mW (Laser Class 2M)
Dimensions (L x W x H)	495 mm x 400 mm x 470 mm
Rated voltage	D.C. 18 V
Net weight	10.2 - 10.5 kg

- Due to our continuing program of research and development, the specifications herein are subject to change without notice.
- Specifications may differ from country to country.
- The weight may differ depending on the attachment(s), including the battery cartridge. The lightest and heaviest combination, according to EPTA-Procedure 01/2014, are shown in the table.

Applicable battery cartridge and charger

Battery cartridge	BL1815N / BL1820 / BL1820B / BL1830 / BL1830B / BL1840 / BL1840B / BL1850 / BL1850B / BL1860B
Charger	DC18RC / DC18RD / DC18RE / DC18SD / DC18SE / DC18SF / DC18SH

- Some of the battery cartridges and chargers listed above may not be available depending on your region of residence.

⚠WARNING: Only use the battery cartridges and chargers listed above. Use of any other battery cartridges and chargers may cause injury and/or fire.

Cutting capacities (H x W) with blade 165 mm in diameter

Miter angle	Bevel angle		
	45° (left)	0°	45° (right)
0°	30 mm x 182 mm	46 mm x 182 mm	15 mm x 182 mm
	36 mm x 150 mm (NOTE 1)	55 mm x 150 mm (NOTE 1)	20 mm x 150 mm (NOTE 1)
45° (left and right)	30 mm x 127 mm	46 mm x 127 mm	15 mm x 127 mm
	36 mm x 100 mm (NOTE 2)	55 mm x 100 mm (NOTE 2)	20 mm x 100 mm (NOTE 2)
57° (right)	–	46 mm x 98 mm	–
	–	55 mm x 80mm (NOTE 3)	–

1. Max. Cutting capacity when using a wood facing 20 mm thickness
2. Max. Cutting capacity when using a wood facing 15 mm thickness
3. Max. Cutting capacity when using a wood facing 10 mm thickness

Symbols

The followings show the symbols used for the equipment. Be sure that you understand their meaning before use.



Read instruction manual.



To avoid injury from flying debris, keep holding the saw head down, after making cuts, until the blade has come to a complete stop.



When performing slide cut, first pull carriage fully and press down handle, then push carriage toward the guide fence.



Do not place hand or fingers close to the blade.



Never look into the laser beam. Direct laser beam may injure your eyes.



Ni-MH
Li-Ion

Only for EU countries
Do not dispose of electric equipment or battery pack together with household waste material!
In observance of the European Directives, on Waste Electric and Electronic Equipment and Batteries and Accumulators and Waste Batteries and Accumulators and their implementation in accordance with national laws, electric equipment and batteries and battery pack(s) that have reached the end of their life must be collected separately and returned to an environmentally compatible recycling facility.

Intended use

The tool is intended for accurate straight and miter cutting in wood. With appropriate saw blades, aluminum can also be sawed.

Do not use the saw to cut other than wood, aluminum or similar materials.

SAFETY WARNINGS

General power tool safety warnings

⚠ WARNING: Read all safety warnings, instructions, illustrations and specifications provided with this power tool. Failure to follow all instructions listed below may result in electric shock, fire and/or serious injury.

Save all warnings and instructions for future reference.

The term "power tool" in the warnings refers to your mains-operated (corded) power tool or battery-operated (cordless) power tool.

Work area safety

1. **Keep work area clean and well lit.** Cluttered or dark areas invite accidents.
2. **Do not operate power tools in explosive atmospheres, such as in the presence of flammable liquids, gases or dust.** Power tools create sparks which may ignite the dust or fumes.
3. **Keep children and bystanders away while operating a power tool.** Distractions can cause you to lose control.

Electrical safety

1. **Power tool plugs must match the outlet. Never modify the plug in any way. Do not use any adapter plugs with earthed (grounded) power tools.** Unmodified plugs and matching outlets will reduce risk of electric shock.
2. **Avoid body contact with earthed or grounded surfaces, such as pipes, radiators, ranges and refrigerators.** There is an increased risk of electric shock if your body is earthed or grounded.
3. **Do not expose power tools to rain or wet conditions.** Water entering a power tool will increase the risk of electric shock.

4. **Do not abuse the cord. Never use the cord for carrying, pulling or unplugging the power tool. Keep cord away from heat, oil, sharp edges or moving parts.** Damaged or entangled cords increase the risk of electric shock.
5. **When operating a power tool outdoors, use an extension cord suitable for outdoor use.** Use of a cord suitable for outdoor use reduces the risk of electric shock.
6. **If operating a power tool in a damp location is unavoidable, use a residual current device (RCD) protected supply.** Use of an RCD reduces the risk of electric shock.
7. **Power tools can produce electromagnetic fields (EMF) that are not harmful to the user.** However, users of pacemakers and other similar medical devices should contact the maker of their device and/or doctor for advice before operating this power tool.

Personal safety

1. **Stay alert, watch what you are doing and use common sense when operating a power tool. Do not use a power tool while you are tired or under the influence of drugs, alcohol or medication.** A moment of inattention while operating power tools may result in serious personal injury.
2. **Use personal protective equipment. Always wear eye protection.** Protective equipment such as a dust mask, non-skid safety shoes, hard hat or hearing protection used for appropriate conditions will reduce personal injuries.
3. **Prevent unintentional starting. Ensure the switch is in the off-position before connecting to power source and/or battery pack, picking up or carrying the tool.** Carrying power tools with your finger on the switch or energising power tools that have the switch on invites accidents.
4. **Remove any adjusting key or wrench before turning the power tool on.** A wrench or a key left attached to a rotating part of the power tool may result in personal injury.
5. **Do not overreach. Keep proper footing and balance at all times.** This enables better control of the power tool in unexpected situations.
6. **Dress properly. Do not wear loose clothing or jewellery. Keep your hair and clothing away from moving parts.** Loose clothes, jewellery or long hair can be caught in moving parts.
7. **If devices are provided for the connection of dust extraction and collection facilities, ensure these are connected and properly used.** Use of dust collection can reduce dust-related hazards.
8. **Do not let familiarity gained from frequent use of tools allow you to become complacent and ignore tool safety principles.** A careless action can cause severe injury within a fraction of a second.
9. **Always wear protective goggles to protect your eyes from injury when using power tools. The goggles must comply with ANSI Z87.1 in the USA, EN 166 in Europe, or AS/NZS 1336 in Australia/New Zealand. In Australia/New Zealand, it is legally required to wear a face shield to protect your face, too.**

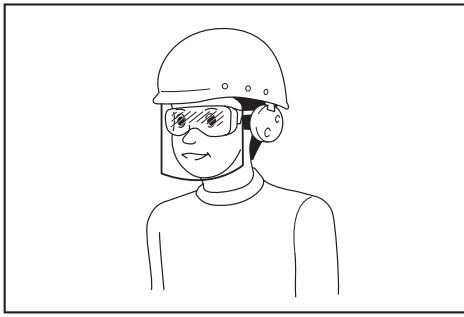

It is an employer's responsibility to enforce the use of appropriate safety protective equipments by the tool operators and by other persons in the immediate working area.

Power tool use and care

- Do not force the power tool. Use the correct power tool for your application.** The correct power tool will do the job better and safer at the rate for which it was designed.
- Do not use the power tool if the switch does not turn it on and off.** Any power tool that cannot be controlled with the switch is dangerous and must be repaired.
- Disconnect the plug from the power source and/or remove the battery pack, if detachable, from the power tool before making any adjustments, changing accessories, or storing power tools.** Such preventive safety measures reduce the risk of starting the power tool accidentally.
- Store idle power tools out of the reach of children and do not allow persons unfamiliar with the power tool or these instructions to operate the power tool.** Power tools are dangerous in the hands of untrained users.
- Maintain power tools and accessories. Check for misalignment or binding of moving parts, breakage of parts and any other condition that may affect the power tool's operation. If damaged, have the power tool repaired before use.** Many accidents are caused by poorly maintained power tools.
- Keep cutting tools sharp and clean.** Properly maintained cutting tools with sharp cutting edges are less likely to bind and are easier to control.
- Use the power tool, accessories and tool bits etc. in accordance with these instructions, taking into account the working conditions and the work to be performed.** Use of the power tool for operations different from those intended could result in a hazardous situation.
- Keep handles and grasping surfaces dry, clean and free from oil and grease.** Slippery handles and grasping surfaces do not allow for safe handling and control of the tool in unexpected situations.
- When using the tool, do not wear cloth work gloves which may be entangled.** The entanglement of cloth work gloves in the moving parts may result in personal injury.

Battery tool use and care

- Recharge only with the charger specified by the manufacturer.** A charger that is suitable for one type of battery pack may create a risk of fire when used with another battery pack.
- Use power tools only with specifically designed battery packs.** Use of any other battery packs may create a risk of injury and fire.
- When battery pack is not in use, keep it away from other metal objects, like paper clips, coins, keys, nails, screws or other small metal objects, that can make a connection from one terminal to another.** Shorting the battery terminals together may cause burns or a fire.
- Under abusive conditions, liquid may be ejected from the battery; avoid contact. If contact accidentally occurs, flush with water. If liquid contacts eyes, additionally seek medical help.** Liquid ejected from the battery may cause irritation or burns.
- Do not use a battery pack or tool that is damaged or modified.** Damaged or modified batteries may exhibit unpredictable behaviour resulting in fire, explosion or risk of injury.
- Do not expose a battery pack or tool to fire or excessive temperature.** Exposure to fire or temperature above 130 °C may cause explosion.
- Follow all charging instructions and do not charge the battery pack or tool outside the temperature range specified in the instructions.** Charging improperly or at temperatures outside the specified range may damage the battery and increase the risk of fire.

Service

- Have your power tool serviced by a qualified repair person using only identical replacement parts.** This will ensure that the safety of the power tool is maintained.
- Never service damaged battery packs.** Service of battery packs should only be performed by the manufacturer or authorized service providers.
- Follow instruction for lubricating and changing accessories.**

Safety instructions for mitre saws

- Mitre saws are intended to cut wood or wood-like products, they cannot be used with abrasive cut-off wheels for cutting ferrous material such as bars, rods, studs, etc.** Abrasive dust causes moving parts such as the lower guard to jam. Sparks from abrasive cutting will burn the lower guard, the kerf insert and other plastic parts.
- Use clamps to support the workpiece whenever possible. If supporting the workpiece by hand, you must always keep your hand at least 100 mm from either side of the saw blade. Do not use this saw to cut pieces that are too small to be securely clamped or held by hand.** If your hand is placed too close to the saw blade, there is an increased risk of injury from blade contact.
- The workpiece must be stationary and clamped or held against both the fence and the table. Do not feed the workpiece into the blade or cut "freehand" in any way.** Unrestrained or moving workpieces could be thrown at high speeds, causing injury.

4. **Push the saw through the workpiece. Do not pull the saw through the workpiece. To make a cut, raise the saw head and pull it out over the workpiece without cutting, start the motor, press the saw head down and push the saw through the workpiece.** Cutting on the pull stroke is likely to cause the saw blade to climb on top of the workpiece and violently throw the blade assembly towards the operator.
5. **Never cross your hand over the intended line of cutting either in front or behind the saw blade.** Supporting the workpiece "cross handed" i.e. holding the workpiece to the right of the saw blade with your left hand or vice versa is very dangerous.

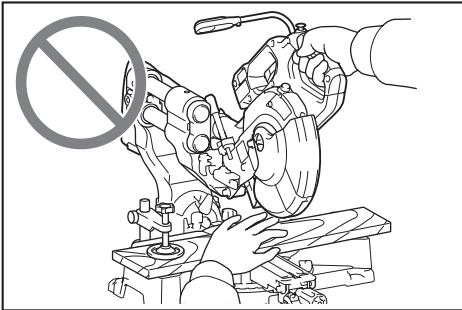

6. **Do not reach behind the fence with either hand closer than 100 mm from either side of the saw blade, to remove wood scraps, or for any other reason while the blade is spinning.** The proximity of the spinning saw blade to your hand may not be obvious and you may be seriously injured.
 7. **Inspect your workpiece before cutting. If the workpiece is bowed or warped, clamp it with the outside bowed face toward the fence. Always make certain that there is no gap between the workpiece, fence and table along the line of the cut.** Bent or warped workpieces can twist or shift and may cause binding on the spinning saw blade while cutting. There should be no nails or foreign objects in the workpiece.
 8. **Do not use the saw until the table is clear of all tools, wood scraps, etc., except for the workpiece.** Small debris or loose pieces of wood or other objects that contact the revolving blade can be thrown with high speed.
 9. **Cut only one workpiece at a time.** Stacked multiple workpieces cannot be adequately clamped or braced and may bind on the blade or shift during cutting.
 10. **Ensure the mitre saw is mounted or placed on a level, firm work surface before use.** A level and firm work surface reduces the risk of the mitre saw becoming unstable.
 11. **Plan your work. Every time you change the bevel or mitre angle setting, make sure the adjustable fence is set correctly to support the workpiece and will not interfere with the blade or the guarding system.** Without turning the tool "ON" and with no workpiece on the table, move the saw blade through a complete simulated cut to assure there will be no interference or danger of cutting the fence.
 12. **Provide adequate support such as table extensions, saw horses, etc. for a workpiece that is wider or longer than the table top.** Workpieces longer or wider than the mitre saw table can tip if not securely supported. If the cut-off piece or workpiece tips, it can lift the lower guard or be thrown by the spinning blade.
 13. **Do not use another person as a substitute for a table extension or as additional support.** Unstable support for the workpiece can cause the blade to bind or the workpiece to shift during the cutting operation pulling you and the helper into the spinning blade.
 14. **The cut-off piece must not be jammed or pressed by any means against the spinning saw blade.** If confined, i.e. using length stops, the cut-off piece could get wedged against the blade and thrown violently.
 15. **Always use a clamp or a fixture designed to properly support round material such as rods or tubing.** Rods have a tendency to roll while being cut, causing the blade to "bite" and pull the work with your hand into the blade.
 16. **Let the blade reach full speed before contacting the workpiece.** This will reduce the risk of the workpiece being thrown.
 17. **If the workpiece or blade becomes jammed, turn the mitre saw off. Wait for all moving parts to stop and disconnect the plug from the power source and/or remove the battery pack. Then work to free the jammed material.** Continued sawing with a jammed workpiece could cause loss of control or damage to the mitre saw.
 18. **After finishing the cut, release the switch, hold the saw head down and wait for the blade to stop before removing the cut-off piece.** Reaching with your hand near the coasting blade is dangerous.
 19. **Hold the handle firmly when making an incomplete cut or when releasing the switch before the saw head is completely in the down position.** The braking action of the saw may cause the saw head to be suddenly pulled downward, causing a risk of injury.
 20. **Only use the saw blade with the diameter that is marked on the tool or specified in the manual.** Use of an incorrectly sized blade may affect the proper guarding of the blade or guard operation which could result in serious personal injury.
 21. **Only use the saw blades that are marked with a speed equal or higher than the speed marked on the tool.**
 22. **Do not use the saw to cut other than wood, aluminum or similar materials.**
 23. **(For European countries only) Always use the blade which conforms to EN847-1.**
- Additional instructions**
1. **Make workshop kid proof with padlocks.**
 2. **Never stand on the tool.** Serious injury could occur if the tool is tipped or if the cutting tool is unintentionally contacted.
 3. **Never leave the tool running unattended. Turn the power off. Do not leave tool until it comes to a complete stop.**

4. Do not operate saw without guards in place. Check blade guard for proper closing before each use. Do not operate saw if blade guard does not move freely and close instantly. Never clamp or tie the blade guard into the open position.
 5. Keep hands out of path of saw blade. Avoid contact with any coasting blade. It can still cause severe injury.
 6. To reduce the risk of injury, return carriage to the full rear position after each crosscut operation.
 7. Always secure all moving portions before carrying the tool.
 8. Stopper pin or stopper lever which locks the saw head down is for carrying and storage purposes only and not for any cutting operations.
 9. Check the blade carefully for cracks or damage before operation. Replace cracked or damaged blade immediately. Gum and wood pitch hardened on blades slows saw and increases potential for kickback. Keep blade clean by first removing it from tool, then cleaning it with gum and pitch remover, hot water or kerosene. Never use gasoline to clean blade.
 10. While making a slide cut, KICKBACK can occur. KICKBACK occurs when the blade binds in the workpiece during a cutting operation and the saw blade is driven rapidly towards the operator. Loss of control and serious personal injury can result. If blade begins to bind during a cutting operation, do not continue to cut and release switch immediately.
 11. Use only flanges specified for this tool.
 12. Be careful not to damage the arbor, flanges (especially the installing surface) or bolt. Damage to these parts could result in blade breakage.
 13. Make sure that the turn base is properly secured so it will not move during operation. Use the holes in the base to fasten the saw to a stable work platform or bench. NEVER use tool where operator positioning would be awkward.
 14. Make sure the shaft lock is released before the switch is turned on.
 15. Be sure that the blade does not contact the turn base in the lowest position.
 16. Hold the handle firmly. Be aware that the saw moves up or down slightly during start-up and stopping.
 17. Make sure the blade is not contacting the workpiece before the switch is turned on.
 18. Before using the tool on an actual workpiece, let it run for a while. Watch for vibration or wobbling that could indicate poor installation or a poorly balanced blade.
 19. Stop operation immediately if you notice anything abnormal.
 20. Do not attempt to lock the trigger in the "ON" position.
 21. Always use accessories recommended in this manual. Use of improper accessories such as abrasive wheels may cause an injury.
 22. Some material contains chemicals which may be toxic. Take caution to prevent dust inhalation and skin contact. Follow material supplier safety data.
 23. Do not use a corded power supply with this tool.
- Additional safety rules for the laser
1. **LASER RADIATION, DO NOT STARE INTO THE BEAM OR VIEW DIRECTLY WITH OPTICAL INSTRUMENTS, CLASS 2M LASER PRODUCT.**

SAVE THESE INSTRUCTIONS.

WARNING: DO NOT let comfort or familiarity with product (gained from repeated use) replace strict adherence to safety rules for the subject product. MISUSE or failure to follow the safety rules stated in this instruction manual may cause serious personal injury.

Important safety instructions for battery cartridge

1. Before using battery cartridge, read all instructions and cautionary markings on (1) battery charger, (2) battery, and (3) product using battery.
2. Do not disassemble battery cartridge.
3. If operating time has become excessively shorter, stop operating immediately. It may result in a risk of overheating, possible burns and even an explosion.
4. If electrolyte gets into your eyes, rinse them out with clear water and seek medical attention right away. It may result in loss of your eyesight.
5. Do not short the battery cartridge:
 - (1) Do not touch the terminals with any conductive material.
 - (2) Avoid storing battery cartridge in a container with other metal objects such as nails, coins, etc.
 - (3) Do not expose battery cartridge to water or rain.

A battery short can cause a large current flow, overheating, possible burns and even a breakdown.
6. Do not store the tool and battery cartridge in locations where the temperature may reach or exceed 50 °C (122 °F).
7. Do not incinerate the battery cartridge even if it is severely damaged or is completely worn out. The battery cartridge can explode in a fire.
8. Be careful not to drop or strike battery.
9. Do not use a damaged battery.
10. The contained lithium-ion batteries are subject to the Dangerous Goods Legislation requirements. For commercial transports e.g. by third parties, forwarding agents, special requirement on packaging and labeling must be observed. For preparation of the item being shipped, consulting an expert for hazardous material is required. Please also observe possibly more detailed national regulations. Tape or mask off open contacts and pack up the battery in such a manner that it cannot move around in the packaging.

11. When disposing the battery cartridge, remove it from the tool and dispose of it in a safe place. Follow your local regulations relating to disposal of battery.
12. Use the batteries only with the products specified by Makita. Installing the batteries to non-compliant products may result in a fire, excessive heat, explosion, or leak of electrolyte.
13. If the tool is not used for a long period of time, the battery must be removed from the tool.
10. The wireless unit is an accurate instrument. Be careful not to drop or strike the wireless unit.
11. Avoid touching the terminal of the wireless unit with bare hands or metallic materials.
12. Always remove the battery on the product when installing the wireless unit into it.
13. When opening the lid of the slot, avoid the place where dust and water may come into the slot. Always keep the inlet of the slot clean.
14. Always insert the wireless unit in the correct direction.
15. Do not press the wireless activation button on the wireless unit too hard and/or press the button with an object with a sharp edge.
16. Always close the lid of the slot when operating.
17. Do not remove the wireless unit from the slot while the power is being supplied to the tool. Doing so may cause a malfunction of the wireless unit.

SAVE THESE INSTRUCTIONS.

⚠CAUTION: Only use genuine Makita batteries. Use of non-genuine Makita batteries, or batteries that have been altered, may result in the battery bursting causing fires, personal injury and damage. It will also void the Makita warranty for the Makita tool and charger.

Tips for maintaining maximum battery life

1. Charge the battery cartridge before completely discharged. Always stop tool operation and charge the battery cartridge when you notice less tool power.
2. Never recharge a fully charged battery cartridge. Overcharging shortens the battery service life.
3. Charge the battery cartridge with room temperature at 10 °C - 40 °C (50 °F - 104 °F). Let a hot battery cartridge cool down before charging it.
4. Charge the battery cartridge if you do not use it for a long period (more than six months).

Important safety instructions for wireless unit

1. Do not disassemble or tamper with the wireless unit.
2. Keep the wireless unit away from young children. If accidentally swallowed, seek medical attention immediately.
3. Use the wireless unit only with Makita tools.
4. Do not expose the wireless unit to rain or wet conditions.
5. Do not use the wireless unit in places where the temperature exceeds 50°C (122°F).
6. Do not operate the wireless unit in places where medical instruments, such as heart pace makers are nearby.
7. Do not operate the wireless unit in places where automated devices are nearby. If operated, automated devices may develop malfunction or error.
8. Do not operate the wireless unit in places under high temperature or places where static electricity or electrical noise could be generated.
9. The wireless unit can produce electromagnetic fields (EMF) but they are not harmful to the user.
18. Do not remove the sticker on the wireless unit.
19. Do not put any sticker on the wireless unit.
20. Do not leave the wireless unit in a place where static electricity or electrical noise could be generated.
21. Do not leave the wireless unit in a place subject to high heat, such as a car sitting in the sun.
22. Do not leave the wireless unit in a dusty or powdery place or in a place corrosive gas could be generated.
23. Sudden change of the temperature may bedew the wireless unit. Do not use the wireless unit until the dew is completely dried.
24. When cleaning the wireless unit, gently wipe with a dry soft cloth. Do not use benzine, thinner, conductive grease or the like.
25. When storing the wireless unit, keep it in the supplied case or a static-free container.
26. Do not insert any devices other than Makita wireless unit into the slot on the tool.
27. Do not use the tool with the lid of the slot damaged. Water, dust, and dirt come into the slot may cause malfunction.
28. Do not pull and/or twist the lid of the slot more than necessary. Restore the lid if it comes off from the tool.
29. Replace the lid of the slot if it is lost or damaged.

SAVE THESE INSTRUCTIONS.

PARTS DESCRIPTION

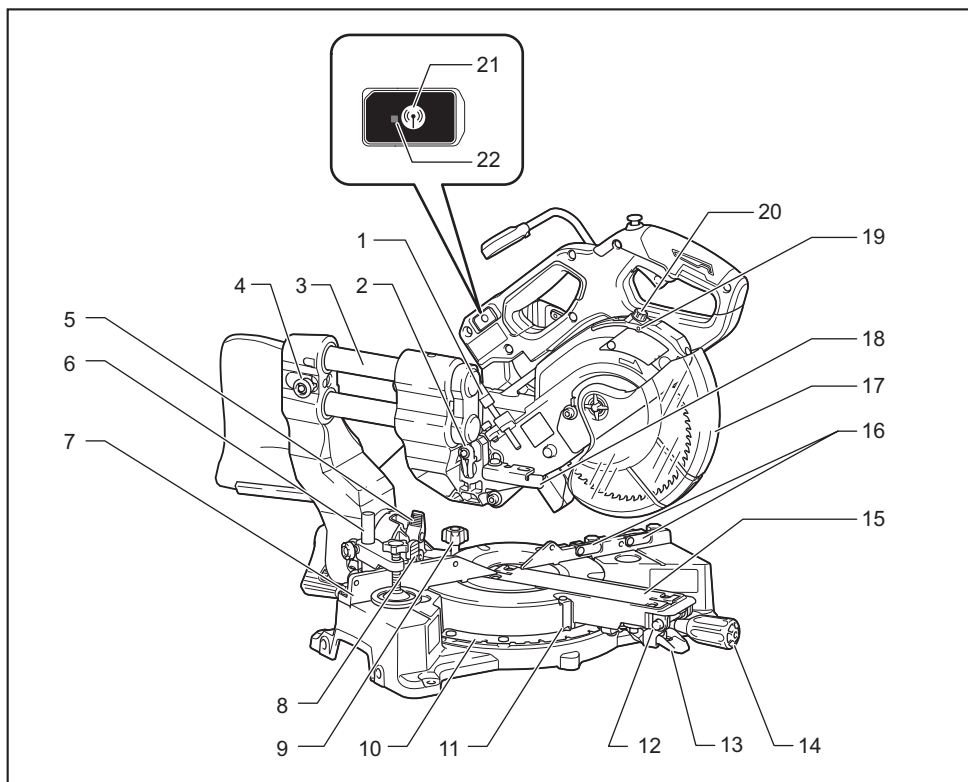

1	Adjusting screw (for lower limit position)	2	Stopper lever (for carriage elevation)	3	Slide pole	4	Stopper pin (for carriage sliding)
5	Releasing lever (for 46° bevel angle)	6	Vertical vise	7	Guide fence	8	Releasing lever (for right side bevel angle)
9	Adjusting knob (for miter angle)	10	Miter angle scale	11	Pointer (for miter angle)	12	Releasing button (for turn base)
13	Lock lever (for turn base)	14	Grip (for turn base)	15	Kerf board	16	Small sub-fence
17	Blade guard	18	Stopper arm	19	Range adjustment screw (for laser line)	20	Adjusting screw (for laser line)
21	Wireless activation button	22	Wireless activation lamp	-	-	-	-

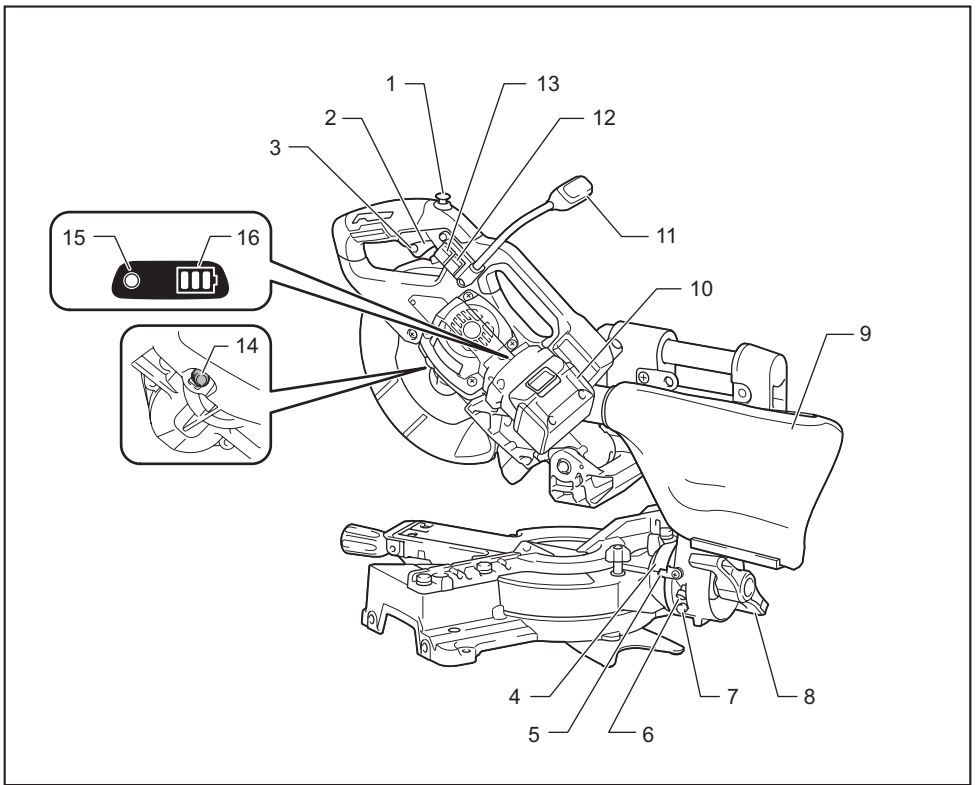

1	Lock-off button	2	Switch trigger	3	Hole for padlock	4	Bevel angle scale
5	Pointer (for bevel angle)	6	45° adjusting bolt (for bevel angle)	7	0° adjusting bolt (for bevel angle)	8	Lever (for bevel angle adjustment)
9	Dust bag	10	Battery cartridge	11	Lamp	12	Lamp switch
13	Laser switch	14	Shaft lock	15	Mode indicator	16	Battery indicator

INSTALLATION

Bench mounting

⚠WARNING: Ensure that the tool does not move on the supporting surface. Movement of the miter saw on the supporting surface while cutting may result in loss of control and serious personal injury.

Fix the base to a level and stable surface, screwing with the bolts. This helps to prevent from tipping and possible injury.

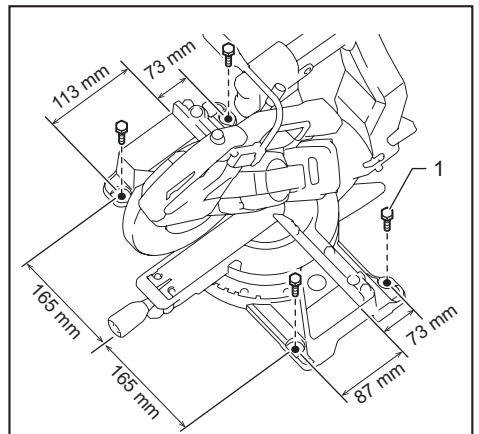

► 1. Bolt

Cutting the kerf board

NOTICE: Finish installing the circular saw blade before performing this procedure. Refer to the section for installing the circular saw blade for details.

For the proper clearance between the kerf board and the circular saw blade, you need to cut the kerf board with the circular saw blade that you are going to use.

1. Unlock the stopper lever and stopper pin to allow the carriage elevated and moved back and forth.

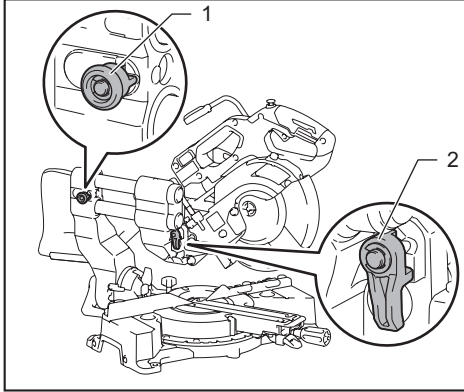

► 1. Stopper pin 2. Stopper lever

2. Prepare a workpiece with 15 mm high, 170 mm wide, and suitable length. Put the workpiece against the guide fence and secure it with the vertical vise.

3. Pull the carriage toward you fully.

4. Switch on the tool without the circular saw blade making any contact and wait until the circular saw blade attains full speed.

5. Press the handle down and push the carriage toward the guide fence and through the workpiece.

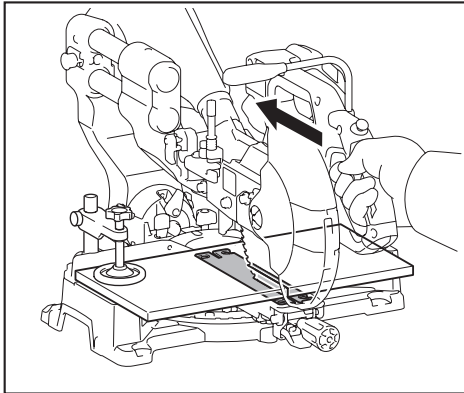

NOTE: When cutting the kerf board, bring the carriage at a slow and even pace.

6. When the cut is completed, switch off the tool and wait until the circular saw blade has come to a complete stop before returning the carriage to its fully elevated position.

7. Turn the lever at the rear of the tool counterclockwise to loosen it.

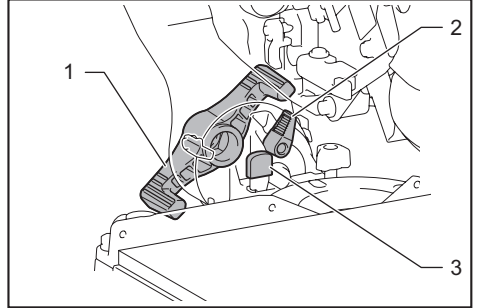

► 1. Lever 2. Releasing lever for 46° bevel angle
3. Releasing lever for right side bevel angle

8. Hold the handle and fully tilt the carriage to the left while keeping the releasing lever for 46° bevel angle fully turned. After that, turn the lever clockwise firmly to tighten it.

9. Perform the cutting procedure in the same way as step 3 to 6.

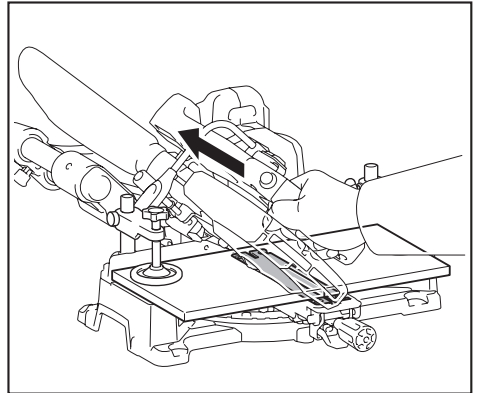

10. Turn the lever at the rear of the tool counterclockwise to loosen it.

11. Hold the handle and tilt the carriage to the left slightly and then tilt to the right while pulling the releasing lever for right side bevel angle. While tilting the carriage to the right, keep the releasing lever for 46° bevel angle fully turned. After that, tighten the lever firmly.

12. Perform the cutting procedure in the same way as step 3 to 6.

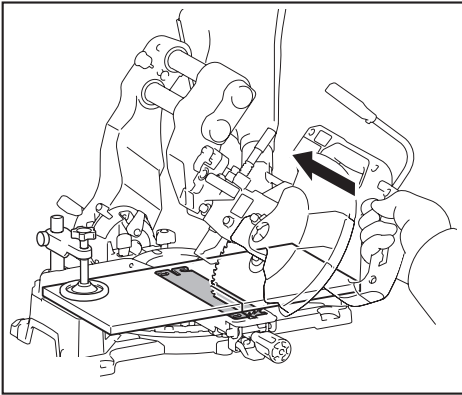

To install the battery cartridge, align the tongue on the battery cartridge with the groove in the housing and slip it into place. Insert it all the way until it locks in place with a little click. If you can see the red indicator on the upper side of the button, it is not locked completely.

⚠ CAUTION: Always install the battery cartridge fully until the red indicator cannot be seen. If not, it may accidentally fall out of the tool, causing injury to you or someone around you.

⚠ CAUTION: Do not install the battery cartridge forcibly. If the cartridge does not slide in easily, it is not being inserted correctly.

Tool / battery protection system

The tool is equipped with a tool/battery protection system. This system automatically cuts off power to the motor to extend tool and battery life. The tool will automatically stop during operation if the tool or battery is placed under one of the following conditions:

Overload protection

When the tool is operated in a manner that causes it to draw an abnormally high current, the tool automatically stops without any indication. In this situation, turn the tool off and stop the application that caused the tool to become overloaded. Then turn the tool on to restart.

Overheat protection

When the tool is overheated, the tool stops automatically, and the battery indicator blinks about 60 seconds. In this situation, let the tool cool down before turning the tool on again.

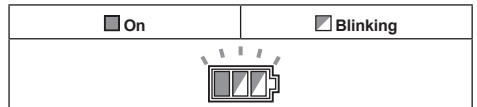

Overdischarge protection

When the battery capacity becomes low, the tool stops automatically. If the product does not operate even when the switches are operated, remove the batteries from the tool and charge the batteries.

Indicating the remaining battery capacity

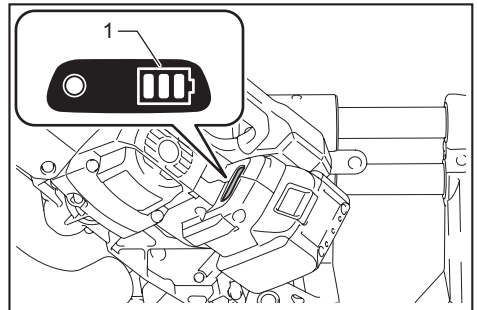

- ▶ 1. Battery indicator

FUNCTIONAL DESCRIPTION

⚠ WARNING: Always be sure that the tool is switched off and the battery cartridge is removed before adjusting or checking the functions on the tool. Failure to switch off and remove the battery cartridge may result in serious personal injury from accidental start-up.

Installing or removing battery cartridge

⚠ CAUTION: Always switch off the tool before installing or removing of the battery cartridge.

⚠ CAUTION: Hold the tool and the battery cartridge firmly when installing or removing battery cartridge. Failure to hold the tool and the battery cartridge firmly may cause them to slip off your hands and result in damage to the tool and battery cartridge and a personal injury.

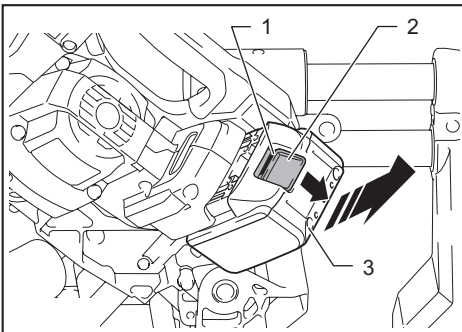

- ▶ 1. Red indicator 2. Button 3. Battery cartridge

To remove the battery cartridge, slide it from the tool while sliding the button on the front of the cartridge.

When you pull the switch trigger, the battery indicator indicates the remaining battery capacity.

Battery indicator status			Remaining battery capacity
On	Off	Blinking	
			50% to 100%
			20% to 50%
			0% to 20%
			Charge the battery

Indicating the remaining battery capacity

Only for battery cartridges with the indicator

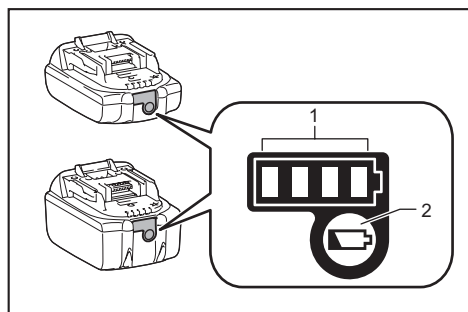

► 1. Indicator lamps 2. Check button

Press the check button on the battery cartridge to indicate the remaining battery capacity. The indicator lamps light up for a few seconds.

Indicator lamps			Remaining capacity
Lighted	Off	Blinking	
			75% to 100%
			50% to 75%
			25% to 50%
			0% to 25%
			Charge the battery.
			The battery may have malfunctioned.

NOTE: Depending on the conditions of use and the ambient temperature, the indication may differ slightly from the actual capacity.

Automatic speed change function

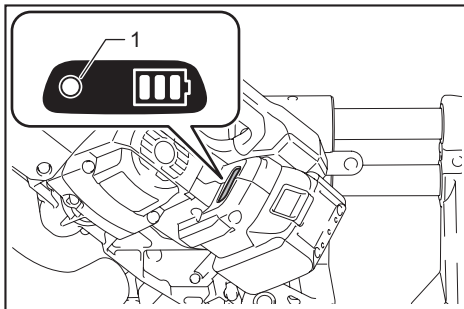

► 1. Mode indicator

Mode indicator status	Operation mode
	High speed mode
	High torque mode

This tool has "high speed mode" and "high torque mode". It automatically changes operation mode depending on the work load. When mode indicator lights up during operation, the tool is in high torque mode.

Stopper lever

CAUTION: Always hold the handle when releasing the stopper lever. Otherwise the handle springs up and it may result in personal injury.

To release the stopper lever, pull the stopper lever and rotate it 90° as illustrated while lowering the handle slightly.

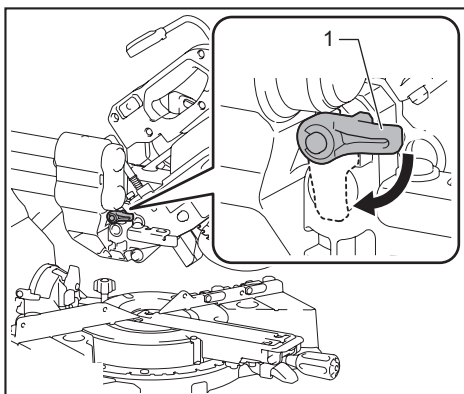

► 1. Stopper lever

Blade guard

⚠ WARNING: Never defeat or remove the blade guard or the spring which attaches to the guard. An exposed blade as a result of defeated guarding may result in serious personal injury during operation.

⚠ WARNING: Never use the tool if the blade guard or spring are damaged, faulty or removed. Operation of the tool with a damaged, faulty or removed guard may result in serious personal injury.

⚠ CAUTION: Always maintain the blade guard in good condition for safe operation. Stop the operation immediately if there are any irregularity of the blade guard. Check to assure spring loaded return action of guard.

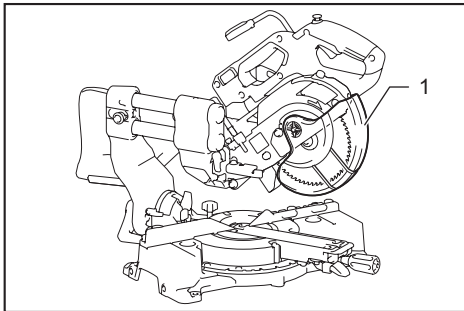

► 1. Blade guard

When lowering the handle, the blade guard raises automatically. The guard is spring loaded so it returns to its original position when the cut is completed and the handle is raised.

Cleaning

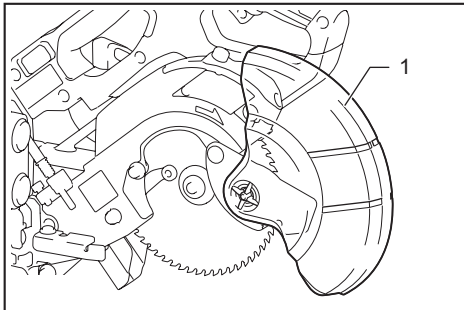

► 1. Blade guard

If the transparent blade guard becomes dirty, or sawdust adheres to it in such a way that the blade and/or workpiece is no longer easily visible, remove the battery cartridge and clean the guard carefully with a damp cloth. Do not use solvents or any petroleum-based cleaners on the plastic guard because this may cause damage to the guard.

For cleaning, raise the blade guard by referring to the section for installing/removing the circular saw blade. After cleaning, make sure to return the circular saw blade and center cover and tighten the hex socket bolt.

1. Make sure that the tool is switched off and the battery cartridge is removed.
2. Turn the hex socket bolt counterclockwise using the supplied hex wrench with holding the center cover.
3. Raise the blade guard and center cover.
4. When cleaning is complete, return the center cover and tighten the hex socket bolt by performing the steps above in reverse.

⚠ WARNING: Do not remove spring holding blade guard. If guard becomes damaged in course of time or UV light exposure, contact a Makita service center for replacement. **DO NOT DEFEAT OR REMOVE GUARD.**

Positioning kerf board

This tool is provided with the kerf boards in the turn base to minimize tearing on the exit side of a cut. Before use, adjust the kerf boards as follows:

1. Make sure to remove the battery cartridge. Then, loosen all the screws (2 each on left and right) securing the kerf boards.

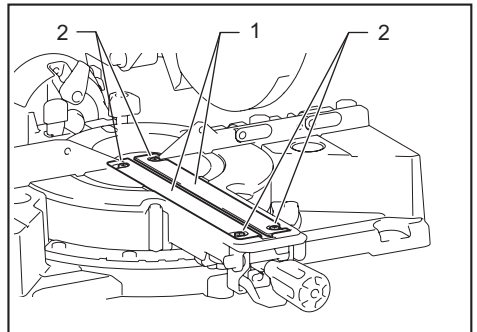

► 1. Kerf board 2. Screw

2. Re-tighten them only to the extent that the kerf boards can still be easily moved by hand.
3. Lower the handle fully and turn the stopper lever to lock the handle in the lowered position.
4. Pull and turn the stopper pin to allow the carriage sliding.

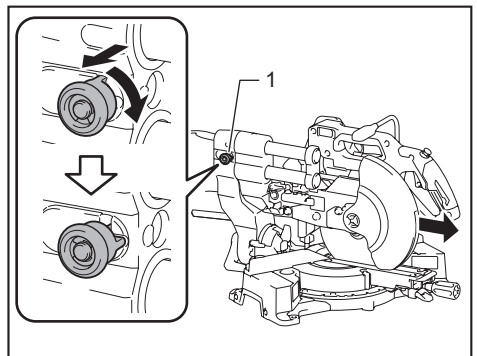

► 1. Stopper pin

5. Pull the carriage toward you fully.
6. Adjust the kerf boards so that the kerf boards just contact the sides of the blade teeth.

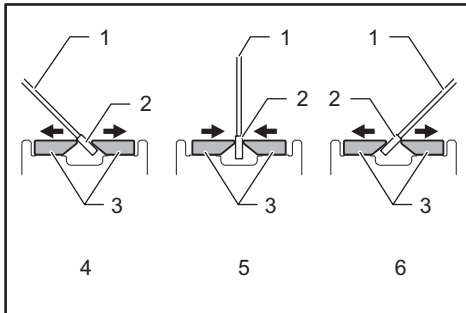
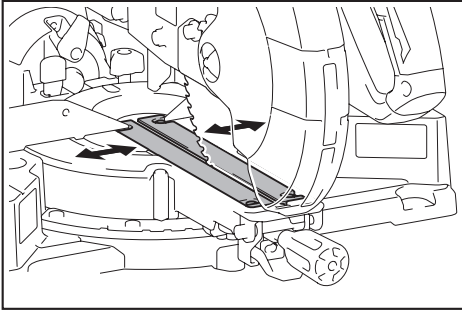

► 1. Saw blade 2. Blade teeth 3. Kerf board 4. Left bevel cut 5. Straight cut 6. Right bevel cut

7. Tighten the front screws (do not tighten firmly).
8. Push the carriage toward the guide fence fully and adjust the kerf boards so that the kerf boards just contact the sides of blade teeth.
9. Tighten the rear screws (do not tighten firmly).
10. After adjusting the kerf boards, release the stopper lever and raise the handle. Then tighten all the screws securely.

NOTICE: After setting the bevel angle, ensure that the kerf boards are adjusted properly. Correct adjustment of the kerf boards helps to provide proper support of the workpiece and minimizing workpiece tear out.

Maintaining maximum cutting capacity

This tool is factory adjusted to provide the maximum cutting capacity for a 165 mm saw blade. When installing a new circular saw blade, always check the lower limit position of the circular saw blade, and if necessary, adjust it as follows:

1. Remove the battery cartridge. Then, push the carriage toward the guide fence fully and lower the handle completely.

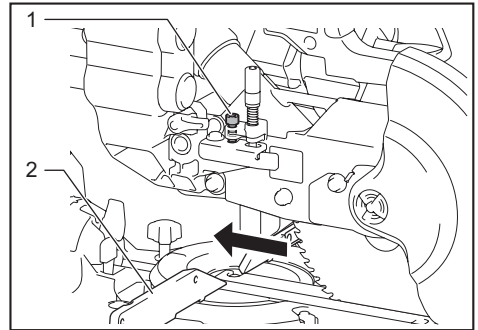

► 1. Adjusting bolt 2. Guide fence

2. Use the hex wrench to turn the adjusting bolt until the circular saw blade comes slightly below the cross section of the guide fence and the top surface of the turn base.

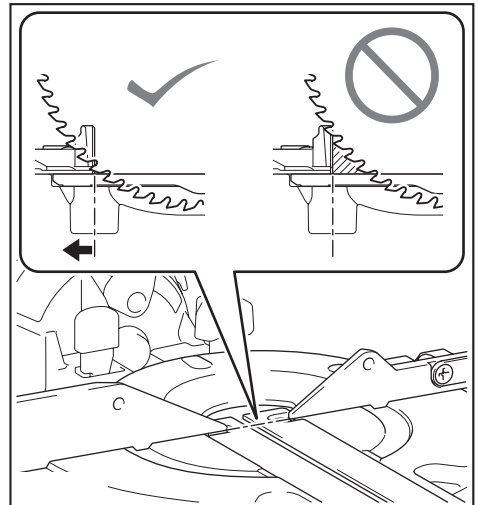

3. Rotate the blade by hand while holding the handle all the way down to be sure that the circular saw blade does not contact any part of the lower base. Re-adjust slightly, if necessary.

⚠WARNING: After installing a new circular saw blade and with the battery cartridge removed, always be sure that the circular saw blade does not contact any part of the lower base when the handle is lowered completely. If a circular saw blade makes contact with the base, it may cause kickback and result in serious personal injury.

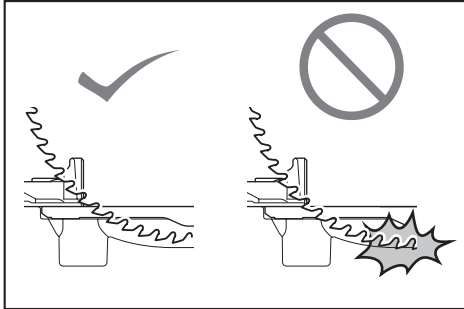

Stopper arm

The lower limit position of the circular saw blade can be easily adjusted with the stopper arm. To adjust it, move the stopper arm in the direction of the arrow as shown in the figure. Turn the adjusting screw with the supplied hex wrench and then press down the handle fully to check the result.

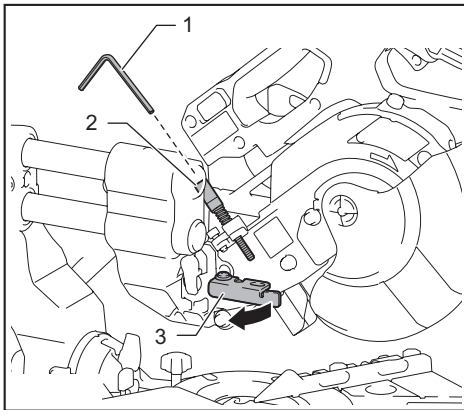

▶ 1. Hex wrench 2. Adjusting screw 3. Stopper arm

⚠CAUTION: Always hold the handle firmly when adjusting. Failure to do so may cause the carriage to jump up and result in injury.

Small sub-fence

⚠CAUTION: When performing right side bevel cuts, fold the small sub-fences. Otherwise, they may contact the circular saw blade or a part of the tool, and may result in serious injury to the operator.

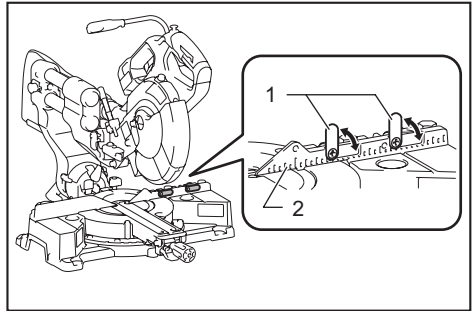

▶ 1. Small sub-fence 2. Scale

When performing vertical cut or left bevel cut, flip them upward to support the workpiece. The guide fence has a scale of 5 mm interval.

Adjusting the miter angle

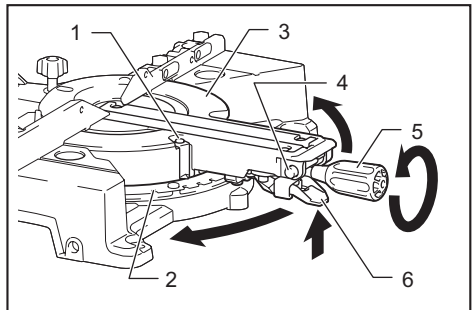

▶ 1. Pointer 2. Miter angle scale 3. Turn base
4. Releasing button 5. Grip 6. Lock lever

1. Loosen the grip counterclockwise.
2. While pulling the lock lever, adjust the angle of the turn base. Use the pointer and the miter angle scale as a guide.
3. Tighten the grip clockwise firmly.

⚠CAUTION: After changing the miter angle, always secure the turn base by tightening the grip firmly.

NOTICE: When turning the turn base, be sure to raise the handle fully.

NOTE: The releasing button enables you to turn the turn base without pulling the lock lever. To engage the releasing button, pull the lock lever and then press the releasing button. While the releasing button is being pressed, release the lock lever. To disengage the releasing button, pull the lock lever again and release it.

NOTE: This miter saw employs positive stop function. You can set 0°, 15°, 22.5°, 30°, and 45° right/left miter angle quickly. To use this function, move the turn base close to your desired positive stop angle while pulling the lock lever. Then release the lock lever and move the turn base to your desired positive stop angle until the turn base is locked.

Using adjusting knob for precise angle setting

You can turn the turn base little by little with the adjusting knob. Loosen the grip and engage the releasing button. Turn the adjusting knob until the pointer indicates your desired miter angle. After that, disengage the releasing button and tighten the grip.

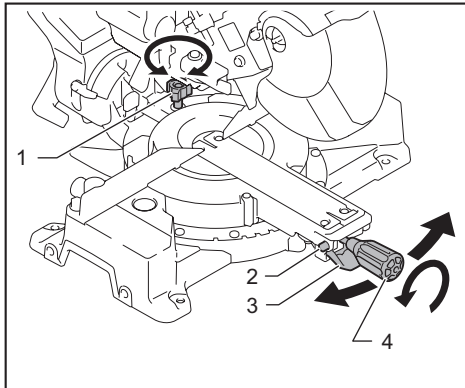

- 1. Adjusting knob 2. Releasing button 3. Lock lever
4. Grip

Adjusting the bevel angle

To adjust the bevel angle, loosen the lever at the rear of the tool.

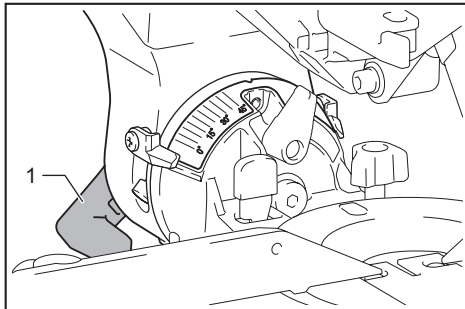

- 1. Lever

To tilt the circular saw blade to the left, hold the handle and tilt the carriage. Use the bevel scale and the pointer as a guide. Then tighten the lever firmly to secure the arm.

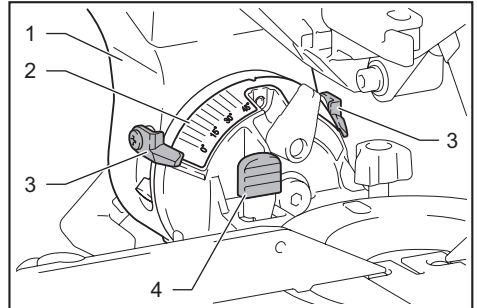

- 1. Arm 2. Bevel scale 3. Pointer 4. Releasing lever for right side bevel angle

To tilt the circular saw blade to the right, hold the handle and tilt the carriage to the left slightly, and then tilt to the right while pulling the releasing lever for right side bevel angle. After that, tighten the lever firmly to secure the arm.

If you perform a bevel cut greater than 45°, tilt the carriage while keeping the releasing lever for 46° bevel angle fully turned. You can perform 46° bevel cut.

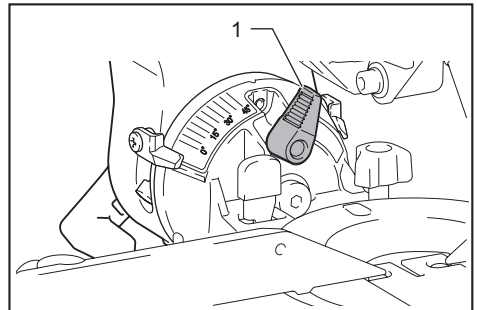

- 1. Releasing lever for 46° bevel angle

CAUTION: After changing the bevel angle, always secure the arm by tightening the lever clockwise.

NOTICE: When tilting the circular saw blade, be sure that the carriage is fully raised.

NOTICE: When changing bevel angles, be sure to position the kerf boards appropriately as explained in the section for positioning kerf boards.

Adjusting the lever position

If the lever does not provide full tightening in course of time, change the position of the lever. The lever can be repositioned at every 10° angle.

Loosen and remove the screw that secures the lever. Remove the lever and install it again so that it points slightly above the horizontal. Then, tighten the lever with the screw firmly.

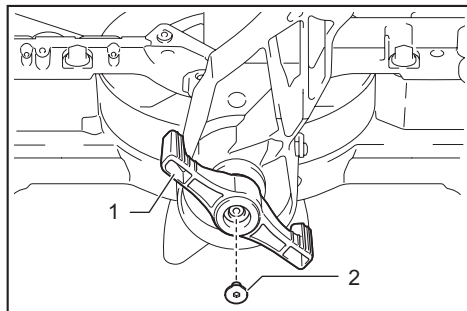

► 1. Lever 2. Screw

Switch action

⚠WARNING: Before installing the battery cartridge(s) into the tool, always check to see that the switch trigger actuates properly and returns to the "OFF" position when released. Do not pull the switch trigger hard without pressing in the lock-off button. This can cause switch breakage. Operating a tool with a switch that does not actuate properly can lead to loss of control and serious personal injury.

⚠WARNING: NEVER use tool without a fully operative switch trigger. Any tool with an inoperative switch is HIGHLY DANGEROUS and must be repaired before further usage or serious personal injury may occur.

⚠WARNING: NEVER defeat the lock-off button by taping down or some other means. A switch with a negated lock-off button may result in unintentional operation and serious personal injury.

⚠WARNING: NEVER use the tool if it runs when you simply pull the switch trigger without pressing the lock-off button. A switch in need of repair may result in unintentional operation and serious personal injury. Return tool to a Makita service center for proper repairs BEFORE further usage.

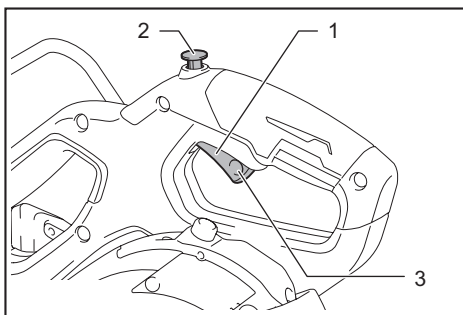

► 1. Switch trigger 2. Lock-off button 3. Hole for padlock

To prevent the switch trigger from being accidentally pulled, a lock-off button is provided. To start the tool, press in the lock-off button and pull the switch trigger. Release the switch trigger to stop.

A hole is provided in the switch trigger for insertion of a padlock to lock the tool off.

⚠WARNING: Do not use a lock with a shank or cable any smaller than 6.35 mm in diameter. A smaller shank or cable may not properly lock the tool in the off position and unintentional operation may occur resulting in serious personal injury.

Lighting up the lamp

⚠CAUTION: The lamp is not a rainproof. Do not wash the lamp in water or use it in a rain or a wet area. Such a conduct can cause an electric shock and fume.

⚠CAUTION: Do not touch the lens of the lamp as it is very hot while it is lighted or shortly after it is turned off. This may cause burns.

⚠CAUTION: Do not apply impact to the lamp, which may cause damage or shorted service time to it.

⚠CAUTION: Do not keep casting the beam of the light to your eyes. This can cause your eyes to be hurt.

⚠CAUTION: Do not cover the lamp with clothes, carton, cardboard or similar objects while it is lighted, which can cause a fire or an ignition.

⚠CAUTION: Do not look in the light or see the source of light directly.

To turn on the light, press the upper position (I) of the lamp switch. To turn off the light, press the lower position (0) of the lamp switch.

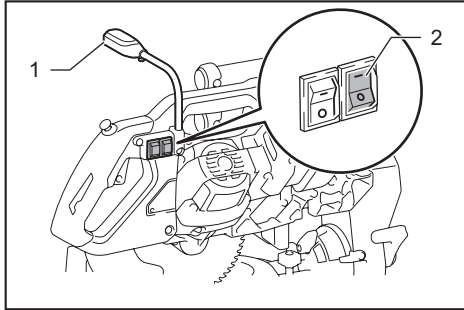

► 1. Lamp 2. Lamp switch

NOTE: Use a dry cloth to wipe the dirt off the lens of the lamp. Be careful not to scratch the lens of lamp, or it may lower the illumination.

NOTE: Be sure to turn off the lamp switch after use because turning on the light consumes the battery power.

Laser beam action

CAUTION: Never look into the laser beam. Direct laser beam may injure your eyes.

To turn on the laser beam, press the upper position (I) of the switch. To turn off the laser beam, press the lower position (0) of the switch.

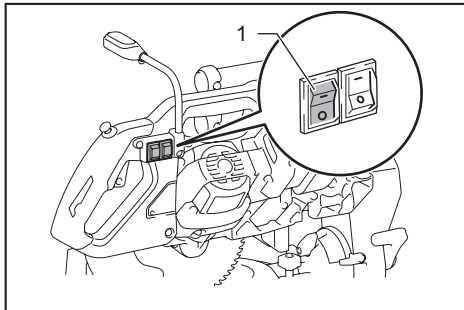

► 1. Laser switch

NOTE: Be sure to turn off the switch as turning on the switch consumes the battery power.

Laser line can be shifted to either the left or right side of the circular saw blade by turning the adjusting screw as follows.

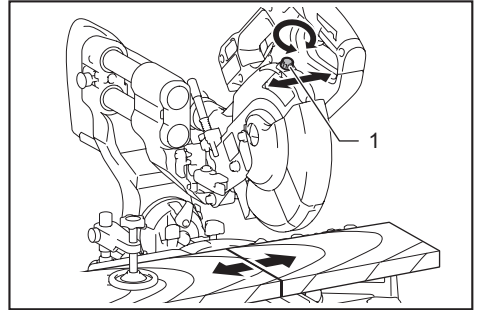

► 1. Adjusting screw

1. Loosen the adjusting screw by turning it counterclockwise.
2. With the adjusting screw loosened, slide the adjusting screw to the right or left as far as it goes.
3. Tighten the adjusting screw firmly at the position where it stops sliding.

NOTE: Laser line is factory adjusted so that it is positioned within 1 mm from the side surface of the circular saw blade (cutting position).

NOTE: When laser line appears dim and hard to see because of direct sunlight, relocate the work area to a place where there is less direct sunlight.

Aligning the laser line

Align the cutting line on your workpiece with the laser line.

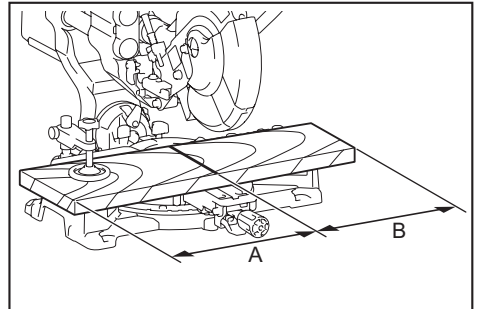

- A) When you want to obtain the correct size on the left side of workpiece, shift the laser line to the left of the circular saw blade.
- B) When you want to obtain the correct size on the right side of workpiece, shift the laser line to the right of the circular saw blade.

Electronic function

Soft start feature

This function allows the smooth start-up of the tool by limiting the start-up torque.

ASSEMBLY

⚠ WARNING: Always be sure that the tool is switched off and the battery cartridge is removed before working on the tool. Failure to switch off and remove the battery cartridge may result in serious personal injury.

Hex wrench storage

When not in use, store the hex wrench as shown in the figure to keep it from being lost.

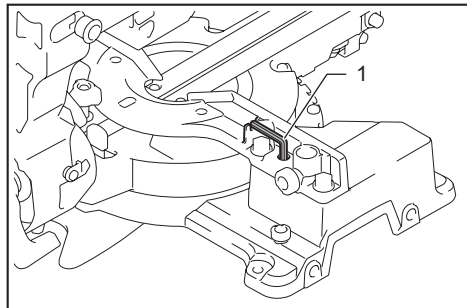

► 1. Hex wrench

Installing or removing saw blade

⚠ WARNING: Always be sure that the tool is switched off and the battery cartridge is removed before installing or removing the circular saw blade. Accidental start up of the tool may result in serious personal injury.

⚠ WARNING: Use only the Makita wrench provided to install or remove the circular saw blade. Failure to use the wrench may result in overtightening or insufficient tightening of the hex socket bolt and serious personal injury.

⚠ WARNING: Never use or substitute the parts which are not supplied with this tool. Using such parts can cause serious personal injury.

⚠ WARNING: After installing the circular saw blade, always make sure that it is securely installed. Loose attachment of the circular saw blade can cause serious personal injury.

To remove the circular saw blade, perform the following steps:

1. Lock the carriage in the raised position by turning the stopper lever as illustrated.

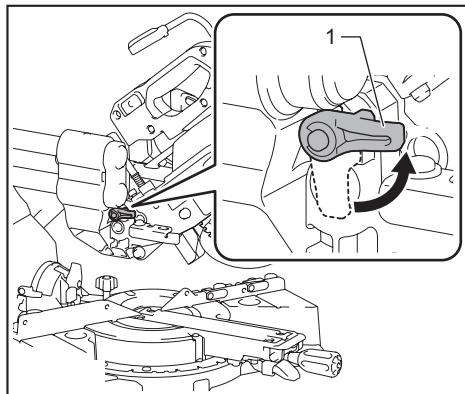

► 1. Stopper lever

2. Use the hex wrench to loosen the hex socket bolt holding the center cover. Then, raise the blade guard and center cover.

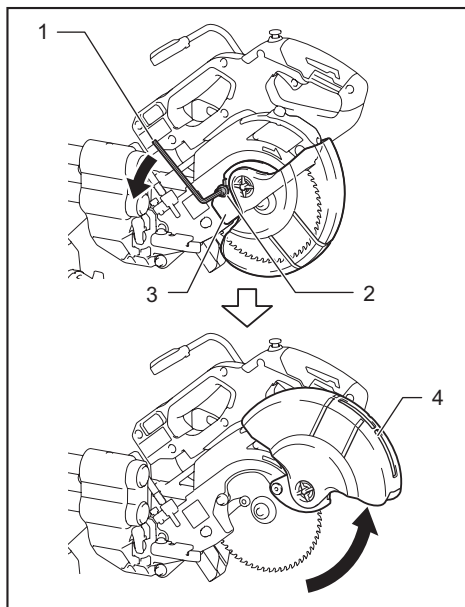

► 1. Hex wrench 2. Hex socket bolt 3. Center cover 4. Blade guard

- Press the shaft lock to lock the spindle and use the hex wrench to loosen the hex socket bolt clockwise. Then remove the hex socket bolt of the spindle, outer flange and circular saw blade.

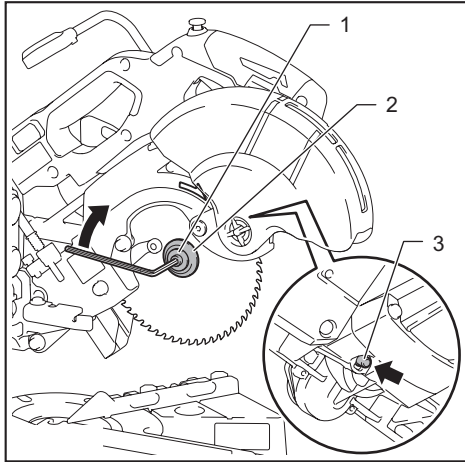

- Hex socket bolt (left-handed)
- Outer flange
- Shaft lock

- If the inner flange is removed, install it on the spindle with its blade mounting part facing the circular saw blade. If the flange is installed incorrectly the flange will rub against the machine.

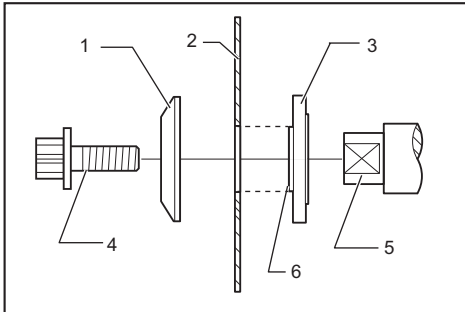

- Outer flange
- Circular saw blade
- Inner flange
- Hex socket bolt (left-handed)
- Spindle
- Blade mounting part

To install the circular saw blade, perform the following steps:

- Mount the circular saw blade carefully onto the inner flange. Make sure that the direction of the arrow on the circular saw blade matches the direction of the arrow on the blade case.

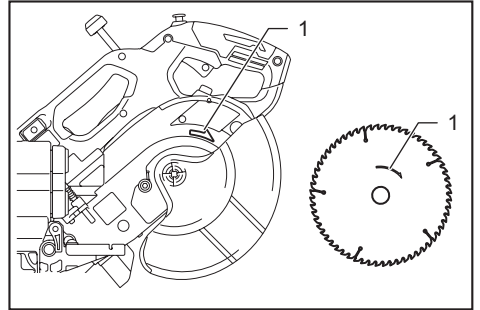

- Arrow

- Install the outer flange and hex socket bolt, and then use the hex wrench to tighten the hex socket bolt (left-handed) of the spindle securely counterclockwise while pressing the shaft lock.
- Return the blade guard and center cover to its original position. Then tighten the hex socket bolt of the center cover to secure it.
- Pull and turn the stopper lever to release the carriage from the raised position. Lower the carriage and check that the blade guard moves properly.
- Make sure the shaft lock has released spindle before making cut.

For tool with the inner flange for 15.88 mm hole-diameter saw blade

Country specific

Mount the inner flange with its recessed side facing outward onto the mounting shaft and then place circular saw blade (with the ring attached if needed), outer flange and hex bolt.

For tool without the ring

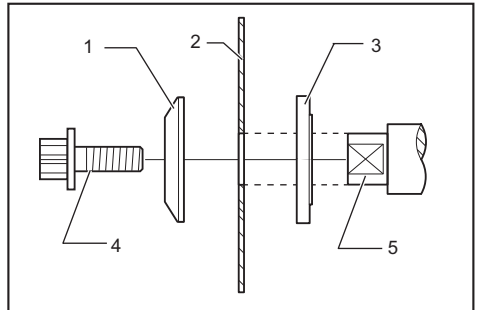

- Outer flange
- Circular saw blade
- Inner flange
- Hex socket bolt (left-handed)
- Spindle

For tool with the ring

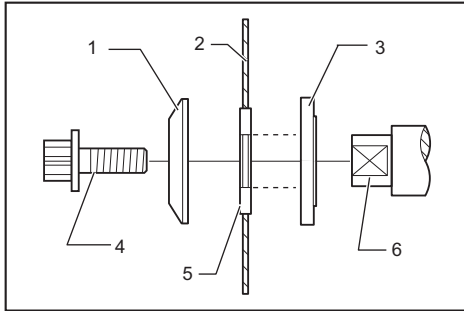

- 1. Outer flange 2. Circular saw blade 3. Inner flange
4. Hex socket bolt (left-handed) 5. Ring 6. Spindle

⚠WARNING: If the ring is needed to mount the circular saw blade onto the spindle, always be sure that the correct ring for the circular saw blade's arbor hole you intend to use is installed between the inner and the outer flanges. Use of the incorrect arbor hole ring may result in the improper mounting of the circular saw blade causing blade movement and severe vibration resulting in possible loss of control during operation and in serious personal injury.

For tool with the inner flange for other than 20 mm or 15.88 mm hole-diameter saw blade

Country specific

The inner flange has a certain diameter of a blade mounting part on one side of it and a different diameter of blade mounting part on the other side. Choose a correct side on which blade mounting part fits into the saw blade hole perfectly.

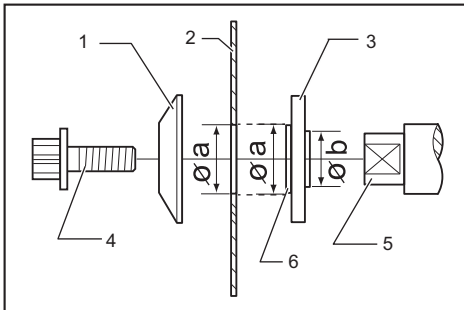

- 1. Outer flange 2. Circular saw blade 3. Inner flange
4. Hex socket bolt (left-handed) 5. Spindle 6. Blade mounting part

⚠CAUTION: Make sure that the blade mounting part "a" on the inner flange that is positioned outside fits into the circular saw blade hole "a" perfectly. Mounting the circular saw blade on the wrong side can result in the dangerous vibration.

Connecting a vacuum cleaner

When you wish to perform clean cutting operation, connect a Makita vacuum cleaner.

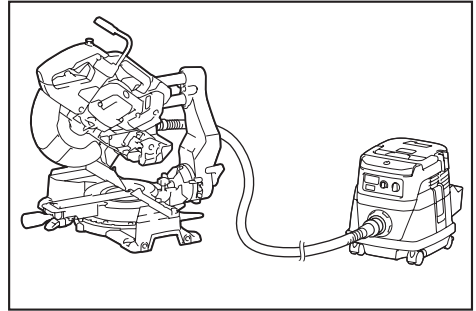

Dust bag

⚠CAUTION: When performing a cutting, always attach the dust bag or connect a vacuum cleaner to prevent dust-related hazards.

The use of the dust bag makes cutting operations cleaner and dust collection easier.

To attach the dust bag, fit it onto the dust nozzle.

To attach the fastener, align the top end of the fastener with the triangular mark on the dust bag.

When the dust bag is about half full, remove the dust bag from the tool and pull the fastener out. Empty the dust bag of its contents, tapping it lightly so as to remove particles adhering to the insides which might hamper further collection.

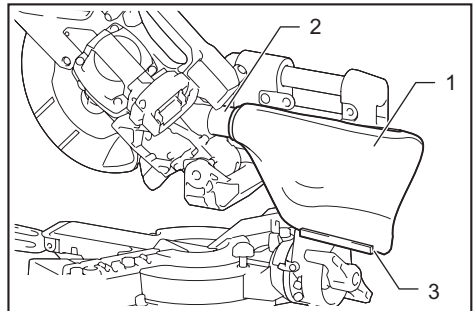

- 1. Dust bag 2. Dust nozzle 3. Fastener

Securing workpiece

⚠ WARNING: It is extremely important to always secure the workpiece correctly with the proper type of vise. Failure to do so may result in serious personal injury and cause damage to the tool and/or the workpiece.

⚠ WARNING: When cutting a workpiece that is longer than the support base of the saw, support the entire length of the material beyond the support base and at the same height to keep the material level. Proper workpiece support helps to avoid blade pinch and possible kickback which may result in serious personal injury. Do not rely solely on the vertical vise and/or horizontal vise to secure the workpiece. Thin material tends to sag. Support workpiece over its entire length to avoid blade pinch and possible KICKBACK.

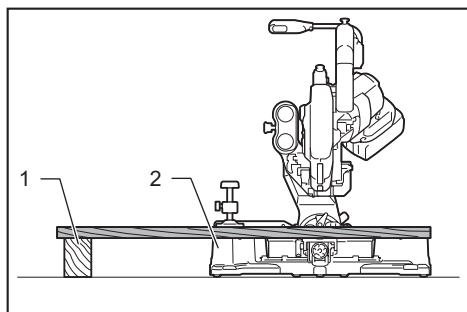

► 1. Support 2. Turn base

Vertical vise

⚠ WARNING: Secure the workpiece firmly against the turn base and guide fence with the vise during all operations. Otherwise the material may move during the cutting operation, cause damage to the circular saw blade, and be thrown which may result in loss of control and serious personal injury.

Install the vertical vise on either the left or right side of the guide fence. Insert the vise rod into the hole in the guide fence and tighten the lower screw to secure the vise rod.

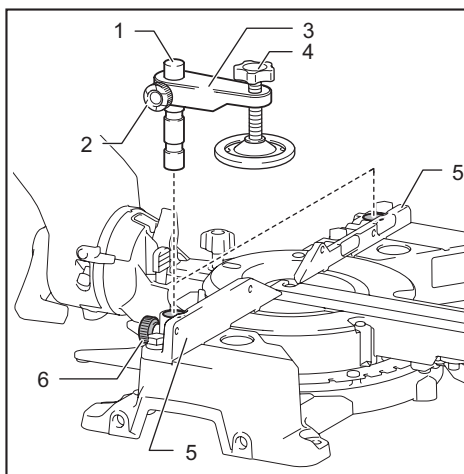

► 1. Vise rod 2. Upper screw 3. Vise arm 4. Vise knob
5. Guide fence 6. Lower screw

Position the vise arm according to the thickness and shape of the workpiece and secure the vise arm by tightening the upper screw. If the upper screw contacts the guide fence, install the upper screw on the opposite side of vise arm. Make sure that no part of the tool contacts the vise when lowering the carriage fully and pulling or pushing the carriage all the way. If a movable part of the tool contacts the vise, re-position the vise. Place the workpiece flat against the guide fence and the turn base. Position the workpiece at the desired cutting position and secure it firmly by tightening the vise knob.

The vertical vise can secure a workpiece up to 55 mm high. If the height of workpiece exceeds 30 mm, lift the vise rod approximately 30 mm and then tighten the vise rod with lower screw.

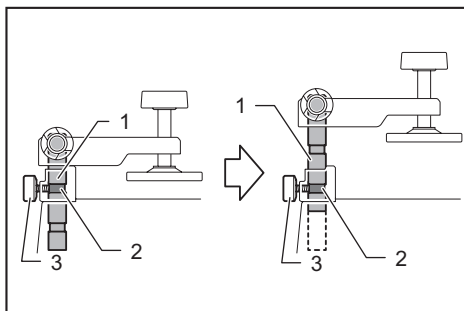

► 1. Vise rod 2. Groove 3. Lower screw

NOTE: The vertical vise can also be installed to the hole on the sub base (optional accessory).

Sub base

Optional accessory

NOTE: The sub base can be installed on either side of the tool.

1. Insert the rods into the holes on the side of the tool. At this time, insert the rod from the end with the groove.

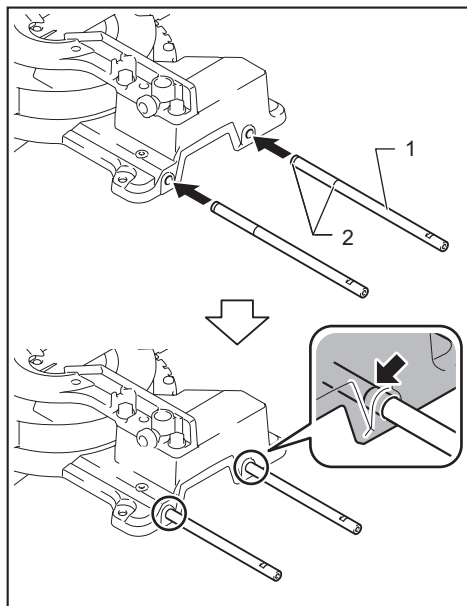

► 1. Rod 2. Groove

2. Secure the sub base with the hex socket bolts. Tighten the hex socket bolt while holding the flat surface on the rod with the wrench.

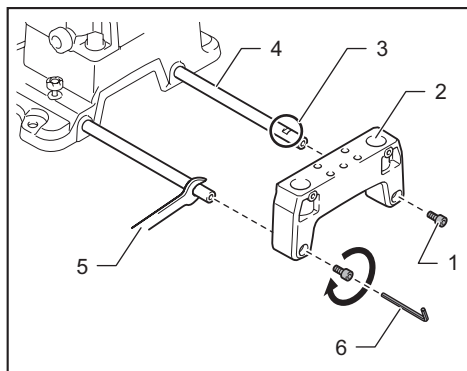

► 1. Hex socket bolt 2. Sub base 3. Flat surface
4. Rod 5. Wrench 6. Hex wrench

NOTE: To tighten the hex socket bolts, use the wrench and hex wrench supplied with the sub base set.

3. Make sure that the groove on the rod cannot be seen and then secure the rod using the clamping screw supplied with the sub base set as illustrated.

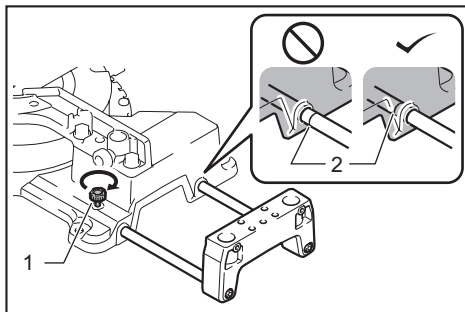

► 1. Clamping screw 2. Groove

4. Attach two fence shafts onto the holes on the sub base using the hex wrench supplied with the tool.

The layout of the fence shaft varies depending on the purpose of cutting.

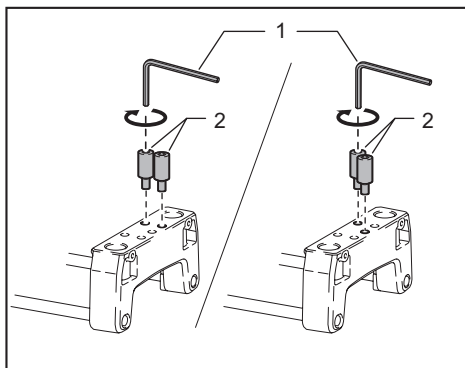

► 1. Hex wrench 2. Fence shaft

When using as a extension fence

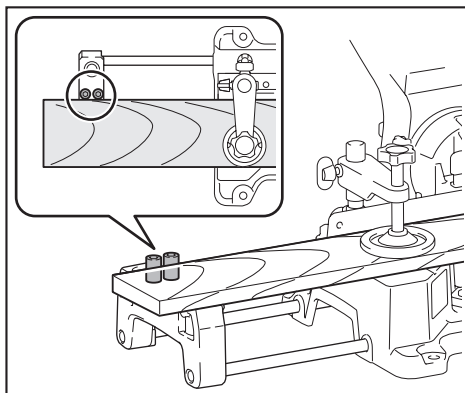

When using as a workpiece support for repetitive cut

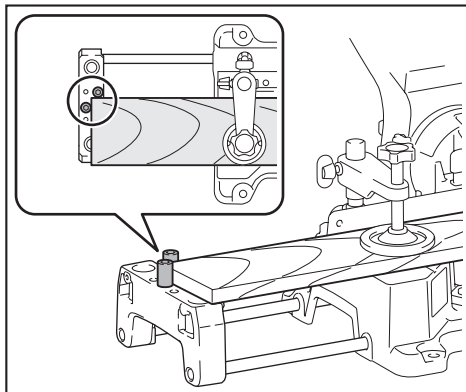

NOTICE: When using the sub base, do not slide out the rod further than the length that the groove on the rod can be seen.

Attaching the shoulder strap

Optional accessory

CAUTION: Be sure to remove the shoulder strap before operating the tool. The shoulder strap may be entangled and cause injury.

CAUTION: Be sure to attach the hooks of the shoulder strap to the tool securely. If the hooks are attached incompletely, they may come off and cause injury.

The shoulder strap is convenient for transporting the tool. Attach the hooks of the shoulder strap to the tool as shown in the figure.

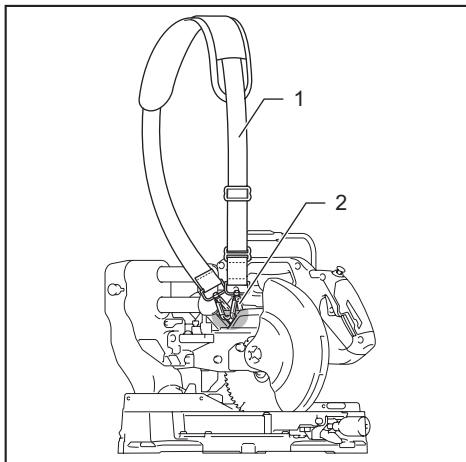

► 1. Shoulder strap 2. Hook

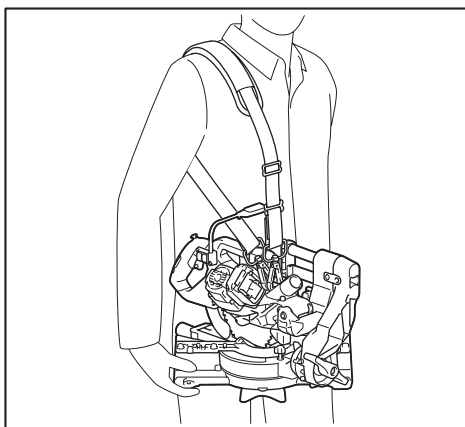

OPERATION

This tool is intended to cut wood products. With appropriate Makita genuine saw blades, following materials can also be sawed :

— Aluminum products

Refer to our website or contact your local Makita dealer for the correct circular saw blades to be used for the material to be cut.

WARNING: Make sure the circular saw blade is not contacting the workpiece, etc. before the switch is turned on. Turning the tool on with the circular saw blade in contact with the workpiece may result in kickback and serious personal injury.

WARNING: After a cutting operation, do not raise the circular saw blade until it has come to a complete stop. The raising of a coasting blade may result in serious personal injury and damage to the workpiece.

WARNING: Do not perform any adjustment such as turning grip, levers, stopper pin on the tool while the circular saw blade is rotating. Adjustment while the circular saw blade is rotating may result in serious personal injury.

NOTICE: Before use, be sure to release the handle from the lowered position by turning the stopper lever.

NOTICE: Do not apply excessive pressure on the handle when cutting. Too much force may result in overload of the motor and/or decreased cutting efficiency. Press down handle with only as much force as necessary for smooth cutting and without significant decrease in blade speed.

NOTICE: Gently press down the handle to perform the cut. If the handle is pressed down with force or if lateral force is applied, the circular saw blade may vibrate and leave a mark (saw mark) in the workpiece and the precision of the cut may be impaired.

NOTICE: During a slide cut, gently push the carriage toward the guide fence without stopping. If the carriage movement stops during the cut, a mark may be left in the workpiece and the precision of the cut may be impaired.

Press cutting

⚠ WARNING: Always lock the sliding movement of the carriage when performing a press cutting. Cutting without lock may cause possible kickback which may result in serious personal injury.

Workpieces up to 46 mm high and 92 mm wide can be cut in the following manner.

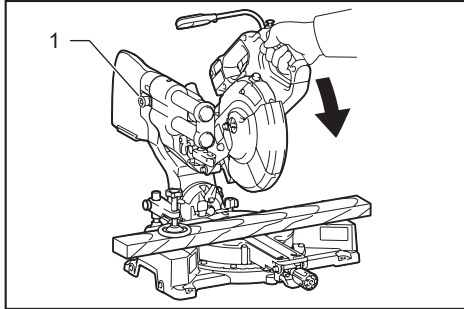

► 1. Stopper pin

1. Push the carriage toward the guide fence until it stops and lock it with the stopper pin.
2. Secure the workpiece with the proper type of vise.
3. Switch on the tool without the circular saw blade making any contact and wait until the circular saw blade attains full speed before lowering.
4. Gently lower the handle to the fully lowered position to cut the workpiece.
5. When the cut is completed, switch off the tool and **wait until the circular saw blade has come to a complete stop** before returning the circular saw blade to its fully elevated position.

Slide (push) cutting (cutting wide workpieces)

⚠ WARNING: Whenever performing a slide cut, first pull the carriage full towards you and press the handle all the way down, then push the carriage toward the guide fence. Never start the cut with the carriage not pulled fully toward you. If you perform the slide cut without the carriage pulled fully toward you, unexpected kickback may occur and serious personal injury may result.

⚠ WARNING: Never attempt to perform a slide cut by pulling the carriage towards you. Pulling the carriage towards you while cutting may cause unexpected kickback resulting in possible serious personal injury.

⚠ WARNING: Never perform the slide cut with the handle locked in the lowered position.

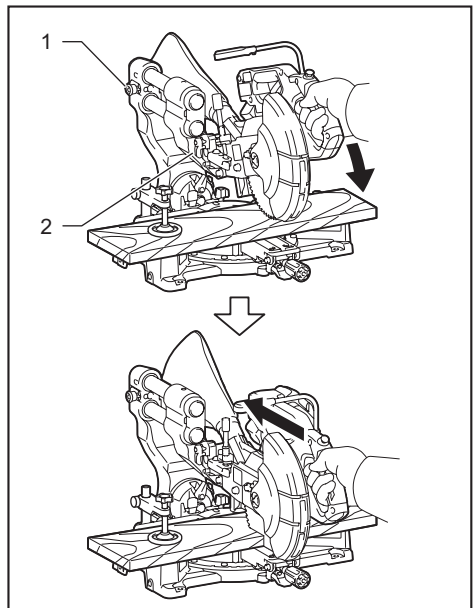

► 1. Stopper pin 2. Stopper lever

1. Unlock the stopper pin and stopper lever so that the carriage can be elevated and slid freely.
2. Secure the workpiece with the proper type of vise.
3. Pull the carriage toward you fully.
4. Switch on the tool without the circular saw blade making any contact and wait until the circular saw blade attains full speed.
5. Press the handle down and **push the carriage toward the guide fence and through the workpiece.**
6. When the cut is completed, switch off the tool and **wait until the circular saw blade has come to a complete stop** before returning the circular saw blade to its fully elevated position.

Miter cutting

Refer to the section for adjusting the miter angle.

Bevel cut

⚠️WARNING: After setting the circular saw blade for a bevel cut, ensure that the carriage and circular saw blade will have free travel throughout the entire range of the intended cut before operating the tool. Interruption of the carriage or circular saw blade travel during the cutting operation may result in kickback and serious personal injury.

⚠️WARNING: While making a bevel cut, keep hands out of the path of the circular saw blade. The angle of the circular saw blade may confuse the operator as to the actual blade path while cutting and contact with the circular saw blade will result in serious personal injury.

⚠️WARNING: The circular saw blade should not be raised until it has come to a complete stop. During a bevel cut, the piece cut off may come to rest against the circular saw blade. If the circular saw blade is raised while it is rotating, the cut-off piece may be ejected by the circular saw blade causing the material to fragment which may result in serious personal injury.

NOTICE: When pressing down the handle, apply pressure in parallel with the circular saw blade. If a force is applied perpendicularly to the turn base or if the pressure direction is changed during a cut, the precision of the cut will be impaired.

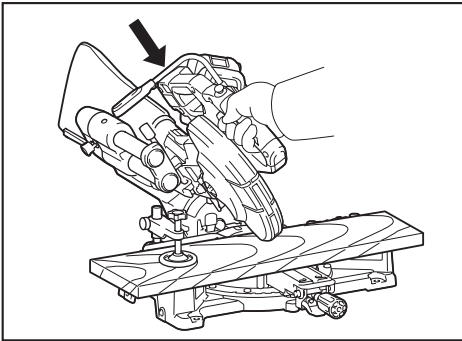

1. Unlock the stopper lever and stopper pin.
2. Adjust the bevel angle according to the procedure explained in the section for bevel angle adjustment. Then tighten the lever.
3. Secure the workpiece with a vise.
4. Pull the carriage toward you fully.
5. Switch on the tool without the circular saw blade making any contact and wait until the circular saw blade attains full speed.
6. Gently lower the handle to the fully lowered position while applying pressure in parallel with the circular saw blade and **push the carriage toward the guide fence to cut the workpiece.**
7. When the cut is completed, switch off the tool and **wait until the circular saw blade has come to a complete stop** before returning the circular saw blade to its fully elevated position.

Compound cutting

Compound cutting is the process in which a bevel angle is made at the same time in which a miter angle is being cut on a workpiece. Compound cutting can be performed at the angle shown in the table.

Miter angle	Bevel angle
Left and Right 45°	Left and Right 0° - 45°
Right 57°	Left 0°, Right 0° - 45°

When performing compound cutting, refer to the section for press cutting, slide (push) cutting, miter cutting, and bevel cut.

Cutting crown and cove moldings

Crown and cove moldings can be cut on a compound miter saw with the moldings laid flat on the turn base. There are two common types of crown moldings and one type of cove moldings; 52/38° wall angle crown molding, 45° wall angle crown molding and 45° wall angle cove molding.

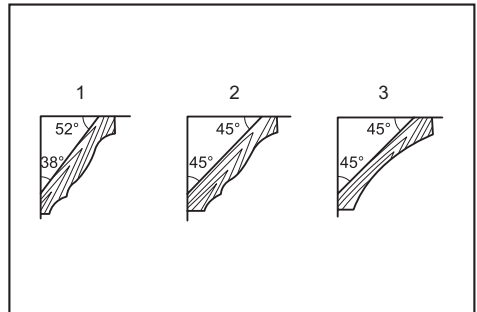

- 1. 52/38° type crown molding 2. 45° type crown molding 3. 45° type cove molding

There are crown and cove molding joints which are made to fit "Inside" 90° corners ((a) and (b) in the figure) and "Outside" 90° corners ((c) and (d) in the figure.)

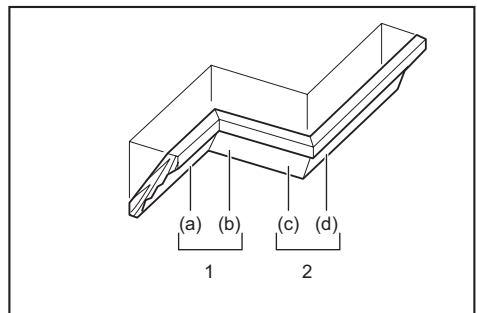

1. Inside corner 2. Outside corner

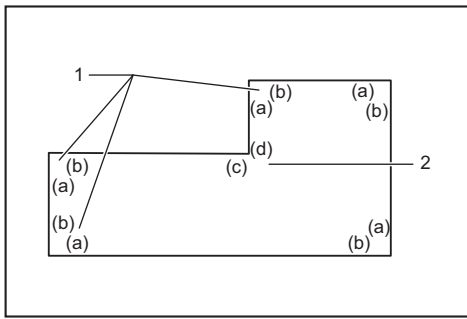

1. Inside corner 2. Outside corner

In the case of left bevel cut

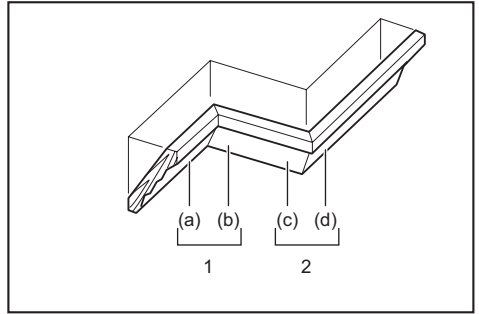

1. Inside corner 2. Outside corner

Measuring

Measure the wall width, and adjust the width of the workpiece according to it. Always make sure that width of the workpiece's wall contact edge is the same as wall length.

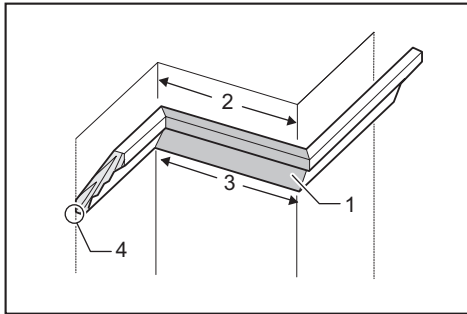

► 1. Workpiece 2. Wall width 3. Width of the workpiece 4. Wall contact edge

Always use several pieces for test cuts to check the saw angles.

When cutting crown and cove moldings, set the bevel angle and miter angle as indicated in the table (A) and position the moldings on the top surface of the saw base as indicated in the table (B).

Table (A)

-	Molding position in the figure	Bevel angle		Miter angle	
		52/38° type	45° type	52/38° type	45° type
For inside corner	(a)	Left 33.9°	Left 30°	Right 31.6°	Right 35.3°
	(b)			Left 31.6°	Left 35.3°
For outside corner	(c)			Right 31.6°	Right 35.3°
	(d)			Right 31.6°	Right 35.3°

Table (B)

-	Molding position in the figure	Molding edge against guide fence	Finished piece
For inside corner	(a)	Ceiling contact edge should be against guide fence.	Finished piece will be on the Left side of blade.
	(b)	Wall contact edge should be against guide fence.	
For outside corner	(c)	Wall contact edge should be against guide fence.	Finished piece will be on the Right side of blade.
	(d)	Ceiling contact edge should be against guide fence.	

Example:

In the case of cutting 52/38° type crown molding for position (a) in the above figure:

- Tilt and secure bevel angle setting to 33.9° LEFT.
- Adjust and secure miter angle setting to 31.6° RIGHT.
- Lay crown molding with its broad back (hidden) surface down on the turn base with its CEILING CONTACT EDGE against the guide fence on the saw.
- The finished piece to be used will always be on the LEFT side of the circular saw blade after the cut has been made.

In the case of right bevel cut

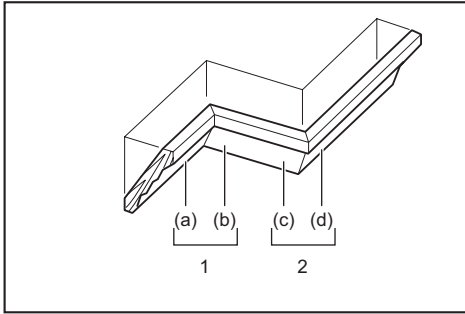

1. Inside corner 2. Outside corner

Table (A)

–	Molding position in the figure	Bevel angle		Miter angle	
		52/38° type	45° type	52/38° type	45° type
For inside corner	(a)	Right 33.9°	Right 30°	Right 31.6°	Right 35.3°
	(b)			Left 31.6°	Left 35.3°
For outside corner	(c)			Right 31.6°	Right 35.3°
	(d)				

Table (B)

–	Molding position in the figure	Molding edge against guide fence	Finished piece
For inside corner	(a)	Wall contact edge should be against guide fence.	Finished piece will be on the Right side of blade.
	(b)	Ceiling contact edge should be against guide fence.	
For outside corner	(c)	Wall contact edge should be against guide fence.	Finished piece will be on the Left side of blade.
	(d)	Ceiling contact edge should be against guide fence.	

Example:

In the case of cutting 52/38° type crown molding for position (a) in the above figure:

- Tilt and secure bevel angle setting to 33.9° RIGHT.
- Adjust and secure miter angle setting to 31.6° RIGHT.
- Lay crown molding with its broad back (hidden) surface down on the turn base with its WALL CONTACT EDGE against the guide fence on the saw.
- The finished piece to be used will always be on the RIGHT side of the circular saw blade after the cut has been made.

Cutting aluminum extrusion

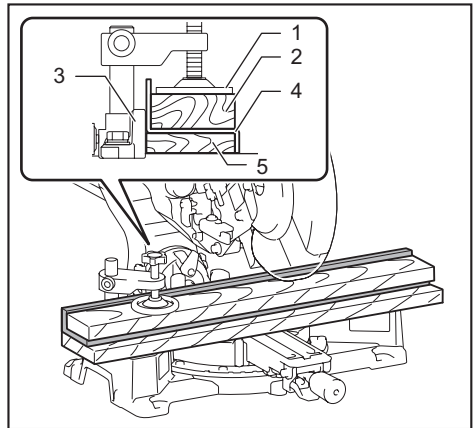

▶ 1. Vise 2. Spacer block 3. Guide fence 4. Aluminum extrusion 5. Spacer block

When securing aluminum extrusions, use spacer blocks or pieces of scrap as shown in the figure to prevent deformation of the aluminum. Use a cutting lubricant when cutting the aluminum extrusion to prevent build-up of the aluminum material on the circular saw blade.

⚠WARNING: Never attempt to cut thick or round aluminum extrusions. Thick or round aluminum extrusions can be difficult to secure and the work may loosen during the cutting operation which may result in loss of control and serious personal injury.

Wood facing

⚠WARNING: Use screws to attach the wood facing to the guide fence. The screws should be installed so that the screw heads are below the surface of the wood facing so that they will not interfere with the positioning of the material being cut. Misalignment of the material being cut can cause unexpected movement during the cutting operation which may result in a loss of control and serious personal injury.

⚠CAUTION: Use the straight wood of even thickness as the wood facing.

Use of wood facing helps to assure splinter-free cuts in workpieces. Attach a wood facing to the guide fence using the holes in the guide fence. See the figure concerning the dimensions for a suggested wood facing.

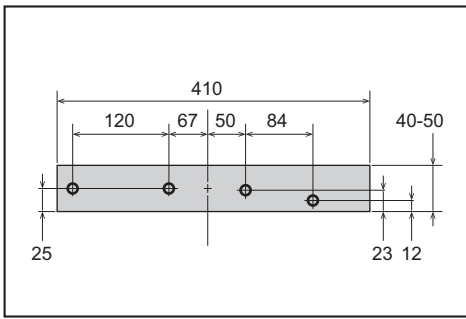

Unit: mm

NOTICE: When the wood facing is attached, do not turn the turn base with the handle lowered. The blade and/or the wood facing will be damaged.

Groove cutting

WARNING: Do not attempt to perform this type of cut by using a wider type blade or dado blade. Attempting to make a groove cut with a wider blade or dado blade could lead to unexpected cutting results and kickback which may result in serious personal injury.

WARNING: Be sure to return the stopper arm to the original position when performing other than groove cutting. Attempting to make cuts with the stopper arm in the incorrect position could lead to unexpected cutting results and kickback which may result in serious personal injury.

For a dado type cut, perform as follows:

1. Adjust the lower limit position of the circular saw blade using the adjusting screw and the stopper arm to limit the cutting depth of the circular saw blade. Refer to the section for stopper arm.
2. After adjusting the lower limit position of the circular saw blade, cut parallel grooves across the width of the workpiece using a slide (push) cut.

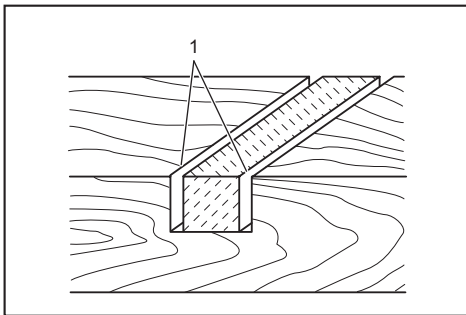

► 1. Cut grooves with blade

3. Remove the workpiece material between the grooves with a chisel.

Carrying tool

Before carrying the tool, be sure to remove the battery cartridge and all movable parts of the miter saw are secured. Always check the following:

- The battery cartridge is removed.
- The carriage is at 0° level angle position and secured.
- The carriage is lowered and locked.
- The carriage is fully slid to the guide fence and locked.
- The turn base is at the full right miter angle position and secured.
- The sub base (optional accessory) is stored and secured.

Carry the tool by the handle or by holding both sides of the tool base.

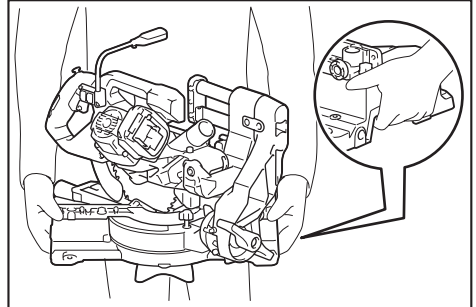
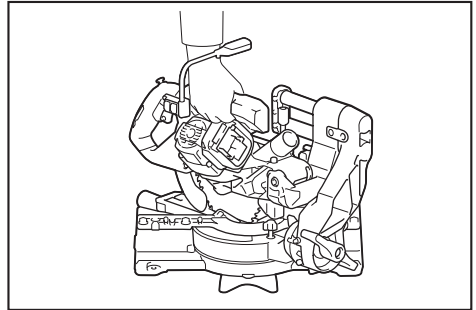

WARNING: Stopper lever for carriage elevation is for carrying and storage purposes only and not for any cutting operations. The use of the stopper lever for cutting operations may cause unexpected movement of the circular saw blade resulting in kickback and serious personal injury.

CAUTION: Always secure all moving portions before carrying the tool. If portions of the tool move or slide while being carried, loss of control or balance may occur and result in personal injury.

CAUTION: Be sure that the carriage elevation is properly locked at its bottom by the stopper lever. If the stopper lever is not engaged properly, the carriage may jump up suddenly and cause personal injury.

WIRELESS ACTIVATION FUNCTION

What you can do with the wireless activation function

The wireless activation function enables clean and comfortable operation. By connecting a supported vacuum cleaner to the tool, you can run the vacuum cleaner automatically along with the switch operation of the tool.

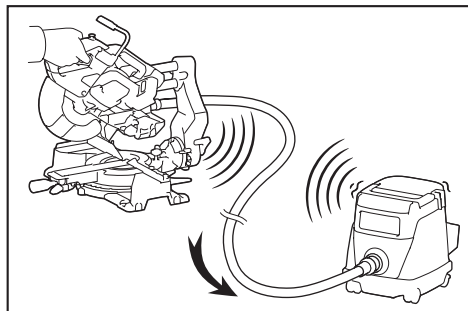

To use the wireless activation function, prepare following items:

- A wireless unit (optional accessory)
- A vacuum cleaner which supports the wireless activation function

The overview of the wireless activation function setting is as follows. Refer to each section for detail procedures.

1. Installing the wireless unit
2. Tool registration for the vacuum cleaner
3. Starting the wireless activation function

Installing the wireless unit

Optional accessory

CAUTION: Place the tool on a flat and stable surface when installing the wireless unit.

NOTICE: Clean the dust and dirt on the tool before installing the wireless unit. Dust or dirt may cause malfunction if it comes into the slot of the wireless unit.

NOTICE: To prevent the malfunction caused by static, touch a static discharging material, such as a metal part of the tool, before picking up the wireless unit.

NOTICE: When installing the wireless unit, always be sure that the wireless unit is inserted in the correct direction and the lid is completely closed.

1. Open the lid on the tool as shown in the figure.

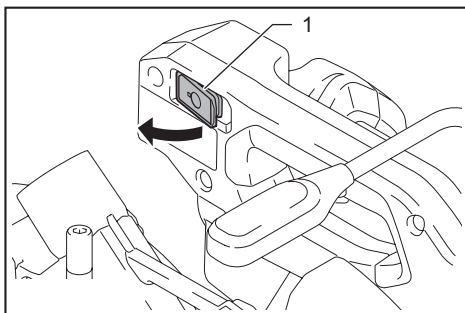

- 1. Lid

2. Insert the wireless unit to the slot and then close the lid.

When inserting the wireless unit, align the projections with the recessed portions on the slot.

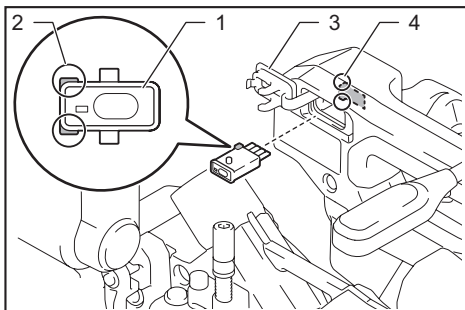

- 1. Wireless unit 2. Projection 3. Lid 4. Recessed portion

When removing the wireless unit, open the lid slowly. The hooks on the back of the lid will lift the wireless unit as you pull up the lid.

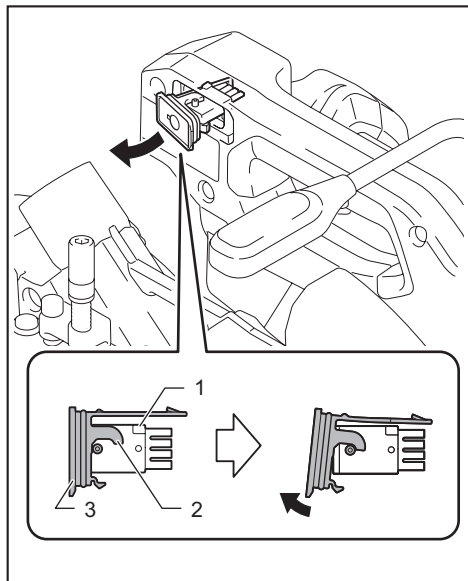

► 1. Wireless unit 2. Hook 3. Lid

After removing the wireless unit, keep it in the supplied case or a static-free container.

NOTICE: Always use the hooks on the back of the lid when removing the wireless unit. If the hooks do not catch the wireless unit, close the lid completely and open it slowly again.

Tool registration for the vacuum cleaner

NOTE: A Makita vacuum cleaner supporting the wireless activation function is required for the tool registration.

NOTE: Finish installing the wireless unit to the tool before starting the tool registration.

NOTE: During the tool registration, do not pull the switch trigger or turn on the power switch on the vacuum cleaner.

NOTE: Refer to the instruction manual of the vacuum cleaner, too.

If you wish to activate the vacuum cleaner along with the switch operation of the tool, finish the tool registration beforehand.

1. Install the batteries to the vacuum cleaner and the tool.

2. Set the stand-by switch on the vacuum cleaner to "AUTO".

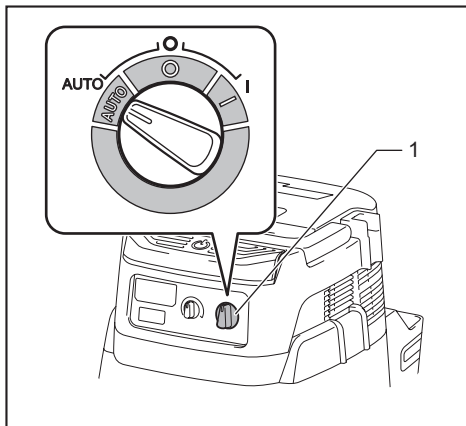

► 1. Stand-by switch

3. Press the wireless activation button on the vacuum cleaner for 3 seconds until the wireless activation lamp blinks in green. And then press the wireless activation button on the tool in the same way.

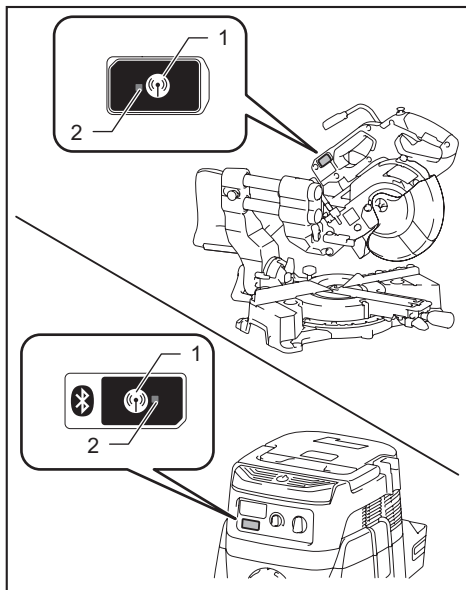

► 1. Wireless activation button 2. Wireless activation lamp

If the vacuum cleaner and the tool are linked successfully, the wireless activation lamps will light up in green for 2 seconds and start blinking in blue.

NOTE: The wireless activation lamps finish blinking in green after 20 seconds elapsed. Press the wireless activation button on the tool while the wireless activation lamp on the cleaner is blinking. If the wireless activation lamp does not blink in green, push the wireless activation button briefly and hold it down again.

NOTE: When performing two or more tool registrations for one vacuum cleaner, finish the tool registration one by one.

Starting the wireless activation function

NOTE: Finish the tool registration for the vacuum cleaner prior to the wireless activation.

NOTE: Refer to the instruction manual of the vacuum cleaner, too.

After registering a tool to the vacuum cleaner, the vacuum cleaner will automatically runs along with the switch operation of the tool.

1. Install the wireless unit to the tool.
2. Connect the hose of the vacuum cleaner with the tool.

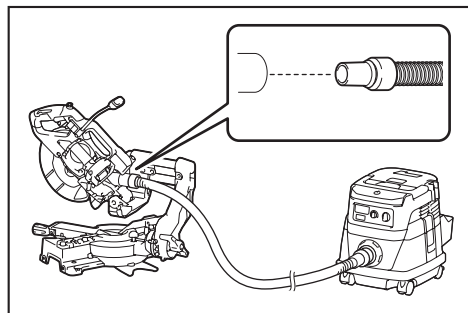

3. Set the stand-by switch on the vacuum cleaner to "AUTO".

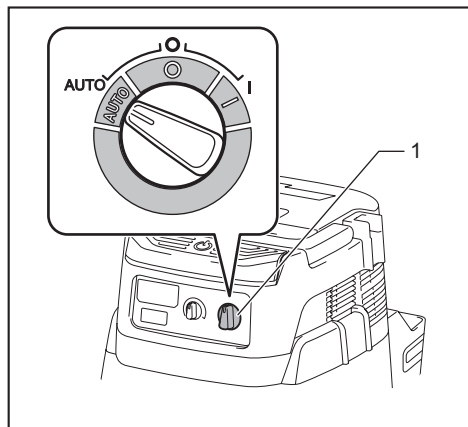

- 1. Stand-by switch

4. Push the wireless activation button on the tool briefly. The wireless activation lamp will blink in blue.

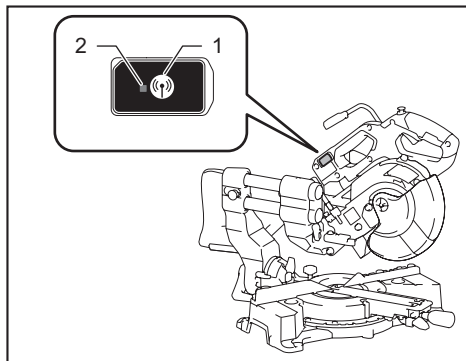

- 1. Wireless activation button 2. Wireless activation lamp

5. Pull the switch trigger of the tool. Check if the vacuum cleaner runs while the switch trigger is being pulled.

To stop the wireless activation of the vacuum cleaner, push the wireless activation button on the tool.

NOTE: The wireless activation lamp on the tool will stop blinking in blue when there is no operation for 2 hours. In this case, set the stand-by switch on the vacuum cleaner to "AUTO" and push the wireless activation button on the tool again.

NOTE: The vacuum cleaner starts/stops with a delay. There is a time lag when the vacuum cleaner detects a switch operation of the tool.

NOTE: The transmission distance of the wireless unit may vary depending on the location and surrounding circumstances.

NOTE: When two or more tools are registered to one vacuum cleaner, the vacuum cleaner may start running even if you don't pull the switch trigger because another user is using the wireless activation function.

Description of the wireless activation lamp status

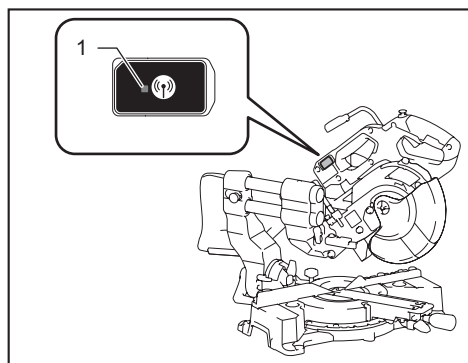

► 1. Wireless activation lamp

The wireless activation lamp shows the status of the wireless activation function. Refer to the table below for the meaning of the lamp status.

Status	Wireless activation lamp				Description
	Color	■ On	■ Blinking	Duration	
Standby	Blue		■	2 hours	The wireless activation of the vacuum cleaner is available. The lamp will automatically turn off when no operation is performed for 2 hours.
			■	When the tool is running.	The wireless activation of the vacuum cleaner is available and the tool is running.
Tool registration	Green		■	20 seconds	Ready for the tool registration. Waiting for the registration by the vacuum cleaner.
			■	2 seconds	The tool registration has been finished. The wireless activation lamp will start blinking in blue.
Cancelling tool registration	Red		■	20 seconds	Ready for the cancellation of the tool registration. Waiting for the cancellation by the vacuum cleaner.
			■	2 seconds	The cancellation of the tool registration has been finished. The wireless activation lamp will start blinking in blue.
Others	Red		■	3 seconds	The power is supplied to the wireless unit and the wireless activation function is starting up.
	Off		-	-	The wireless activation of the vacuum cleaner is stopped.

Cancelling tool registration for the vacuum cleaner

Perform the following procedure when cancelling the tool registration for the vacuum cleaner.

1. Install the batteries to the vacuum cleaner and the tool.
2. Set the stand-by switch on the vacuum cleaner to "AUTO".

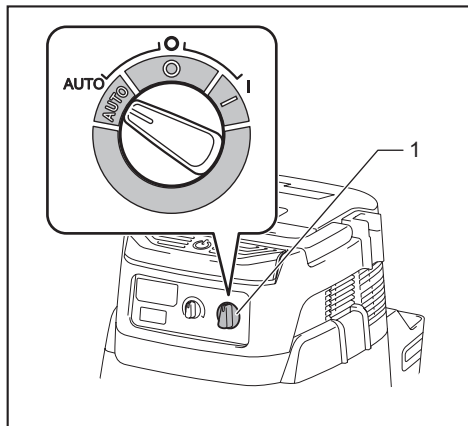

► 1. Stand-by switch

3. Press the wireless activation button on the vacuum cleaner for 6 seconds. The wireless activation lamp blinks in green and then become red. After that, press the wireless activation button on the tool in the same way.

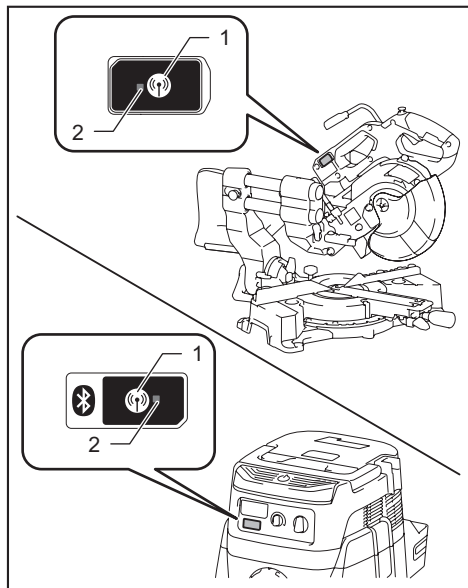

► 1. Wireless activation button 2. Wireless activation lamp

If the cancellation is performed successfully, the wireless activation lamps will light up in red for 2 seconds and start blinking in blue.

NOTE: The wireless activation lamps finish blinking in red after 20 seconds elapsed. Press the wireless activation button on the tool while the wireless activation lamp on the cleaner is blinking. If the wireless activation lamp does not blink in red, push the wireless activation button briefly and hold it down again.

Troubleshooting for wireless activation function

Before asking for repairs, conduct your own inspection first. If you find a problem that is not explained in the manual, do not attempt to dismantle the tool. Instead, ask Makita Authorized Service Centers, always using Makita replacement parts for repairs.

State of abnormality	Probable cause (malfunction)	Remedy
The wireless activation lamp does not light/blink.	The wireless unit is not installed into the tool. The wireless unit is improperly installed into the tool.	Install the wireless unit correctly.
	The terminal of the wireless unit and/or the slot is dirty.	Gently wipe off dust and dirt on the terminal of the wireless unit and clean the slot.
	The wireless activation button on the tool has not been pushed.	Push the wireless activation button on the tool briefly.
	The stand-by switch on the vacuum cleaner is not set to "AUTO".	Set the stand-by switch on the vacuum cleaner to "AUTO".
	No power supply	Supply the power to the tool and the vacuum cleaner.
Cannot finish tool registration / cancelling tool registration successfully.	The wireless unit is not installed into the tool. The wireless unit is improperly installed into the tool.	Install the wireless unit correctly.
	The terminal of the wireless unit and/or the slot is dirty.	Gently wipe off dust and dirt on the terminal of the wireless unit and clean the slot.
	The stand-by switch on the vacuum cleaner is not set to "AUTO".	Set the stand-by switch on the vacuum cleaner to "AUTO".
	No power supply	Supply the power to the tool and the vacuum cleaner.
	Incorrect operation	Push the wireless activation button briefly and perform the tool registration/cancellation procedures again.
	The tool and vacuum cleaner are away from each other (out of the transmission range).	Get the tool and vacuum cleaner closer to each other. The maximum transmission distance is approximately 10 m however it may vary according to the circumstances.
	Before finishing the tool registration/cancellation; - the switch trigger on the tool is pulled or; - the power button on the vacuum cleaner is turned on.	Push the wireless activation button briefly and perform the tool registration/cancellation procedures again.
	The tool registration procedures for the tool or vacuum cleaner have not finished.	Perform the tool registration procedures for both the tool and the vacuum cleaner at the same timing.
Radio disturbance by other appliances which generate high-intensity radio waves.	Keep the tool and vacuum cleaner away from the appliances such as Wi-Fi devices and microwave ovens.	
The vacuum cleaner does not run along with the switch operation of the tool.	The wireless unit is not installed into the tool. The wireless unit is improperly installed into the tool.	Install the wireless unit correctly.
	The terminal of the wireless unit and/or the slot is dirty.	Gently wipe off dust and dirt on the terminal of the wireless unit and clean the slot.
	The wireless activation button on the tool has not been pushed.	Push the wireless activation button briefly and make sure that the wireless activation lamp is blinking in blue.
	The stand-by switch on the vacuum cleaner is not set to "AUTO".	Set the stand-by switch on the vacuum cleaner to "AUTO".
	More than 10 tools are registered to the vacuum cleaner.	Perform the tool registration again. If more than 10 tools are registered to the vacuum cleaner, the tool registered earliest will be cancelled automatically.
	The vacuum cleaner erased all tool registrations.	Perform the tool registration again.
	No power supply	Supply the power to the tool and the vacuum cleaner.
	The tool and vacuum cleaner are away from each other (out of the transmission range).	Get the tool and vacuum cleaner closer each other. The maximum transmission distance is approximately 10 m however it may vary according to the circumstances.
	Radio disturbance by other appliances which generate high-intensity radio waves.	Keep the tool and vacuum cleaner away from the appliances such as Wi-Fi devices and microwave ovens.
The vacuum cleaner runs while the tool's switch trigger is not pulled.	Other users are using the wireless activation of the vacuum cleaner with their tools.	Turn off the wireless activation button of the other tools or cancel the tool registration of the other tools.

MAINTENANCE

⚠ WARNING: Always be sure that the tool is switched off and the battery cartridge is removed before attempting to perform inspection or maintenance. Failure to removing the battery cartridge and switch off the tool may result in accidental start up of the tool which may result in serious personal injury.

⚠ WARNING: Always be sure that the circular saw blade is sharp and clean for the best and safest performance. Attempting a cut with a dull and /or dirty blade may cause kickback and result in a serious personal injury.

NOTICE: Never use gasoline, benzine, thinner, alcohol or the like. Discoloration, deformation or cracks may result.

To maintain product SAFETY and RELIABILITY, repairs, any other maintenance or adjustment should be performed by Makita Authorized or Factory Service Centers, always using Makita replacement parts.

Adjusting the cutting angle

This tool is carefully adjusted and aligned at the factory, but rough handling may have affected the alignment. If your tool is not aligned properly, perform the following:

Miter angle

Lower the carriage fully and lock it in the lowered position by the stopper lever. Push the carriage toward the guide fence. Loosen the grip and the screws which secure the pointer and miter angle scale.

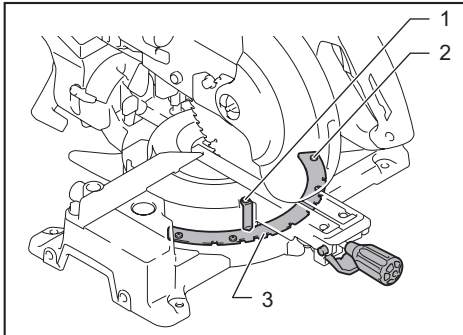

- 1. Screw on pointer 2. Screws on miter angle scale
3. Miter angle scale

Set the turn base to the 0° position using the positive stop function. Square the side of the circular saw blade with the face of the guide fence using a triangular rule or try-square. While keeping the square, tighten the screws on the miter angle scale. After that, align the pointers (both right and left) with the 0° position in the miter angle scale and then tighten the screw on the pointer.

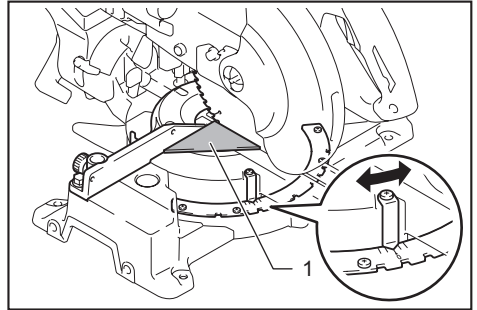

- 1. Triangular rule

Bevel angle

0° bevel angle

Push the carriage toward the guide fence and lock the sliding movement by the stopper pin. Lower the carriage fully and lock it in the lowered position by the stopper lever and then loosen the lever on the back of the tool. Turn the 0° adjusting bolt two or three revolutions counterclockwise to tilt the circular saw blade to the right.

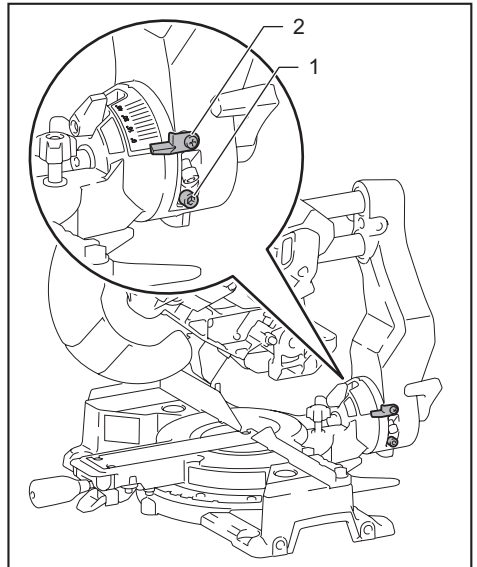

- 1. 0° Adjusting bolt 2. Screw on the pointer

Carefully square the side of the circular saw blade with the top surface of the turn base using the triangular rule, try-square, etc. by turning the 0° adjusting bolt clockwise. Then tighten the lever firmly to secure the 0° angle you have set.

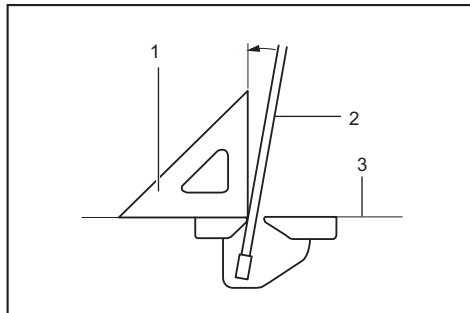

► 1. Triangular rule 2. Saw blade 3. Top surface of turn base

Check if the side of the circular saw blade squares with the turn base surface once again. Loosen the screw on the pointer. Align the pointer in the bevel angle scale with 0° position and then tighten the screw.

45° bevel angle

NOTICE: Before adjusting the 45° bevel angle, finish 0° bevel angle adjustment.

Loosen the lever and fully tilt the carriage to the side that you want to check. Check if the pointer indicates the 45° position in the bevel angle scale.

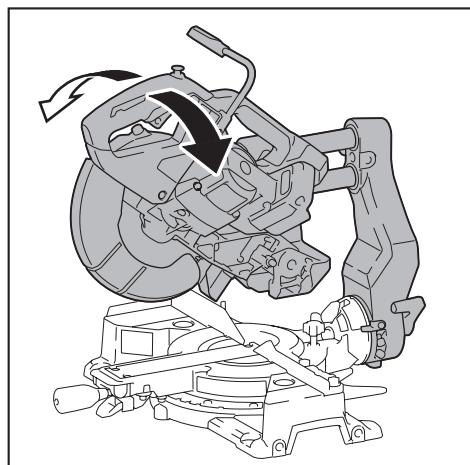

If the pointer does not indicate the 45° position, align it with 45° position by turning the adjusting bolt.

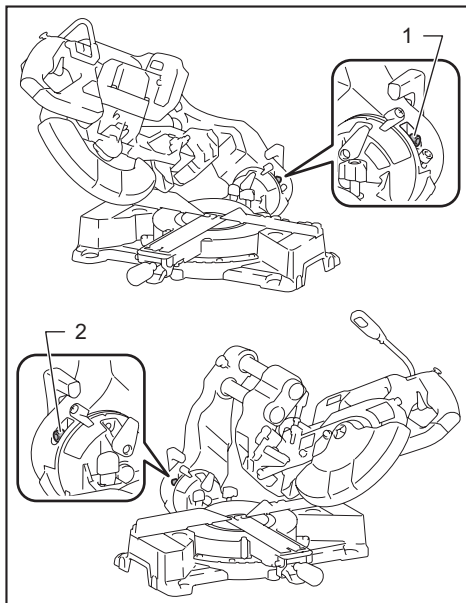

► 1. Left 45° adjusting bolt 2. Right 45° adjusting bolt

Adjusting the laser line position

WARNING: The battery cartridge must be installed while adjusting the laser line. Take extra care not to switch on the tool during adjustment. Accidental start up of the tool may result in serious personal injury.

CAUTION: Never look directly into the laser beam. Direct eye exposure to the beam could cause serious damage to your eyes.

NOTICE: Check the position of laser line regularly for accuracy.

NOTICE: Beware that impacts to the tool. It may cause the laser line to be misaligned or may cause damage to the laser, shortening its life.

NOTICE: Have the tool repaired by a Makita authorized service center for any failure on the laser unit.

The movable range of laser line is decided by the range adjustment screws on both sides. Perform following procedures to alter the laser line position.

1. Remove the battery cartridge.
2. Draw a cutting line on the workpiece and place it on the turn base. At this time, do not secure the workpiece with a vise or similar securing device.
3. Lower the carriage and align the cutting line with the circular saw blade.
4. Return the carriage to the original position and secure the workpiece with the vertical vise so that the workpiece does not move from the position you have determined.

5. Install the battery cartridge and turn on the laser switch.
6. Loosen the adjusting screw. To move the laser line away from the circular saw blade, turn the range adjustment screws counterclockwise. To move the laser line close to the circular saw blade, turn the range adjustment screw clockwise.

Adjusting the laser line on the left side of the circular saw blade

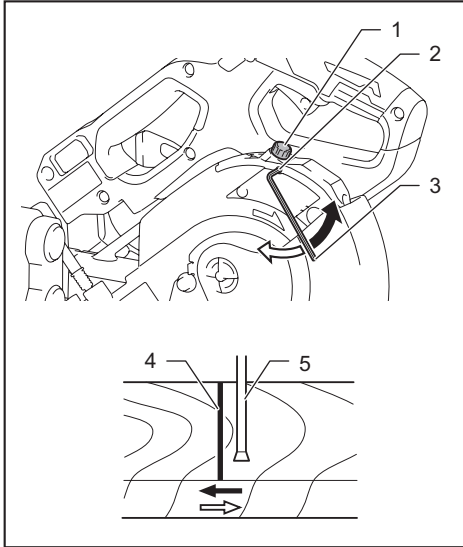

- 1. Adjusting screw 2. Range adjustment screw
3. Hex wrench 4. Laser line 5. Circular saw blade

Adjusting the laser line on the right side of the circular saw blade

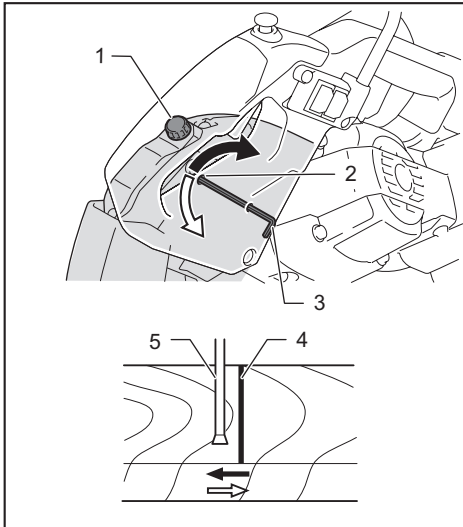

- 1. Adjusting screw 2. Range adjustment screw
3. Hex wrench 4. Laser line 5. Circular saw blade

7. Slide the adjusting screw to the position that the laser line comes onto the cutting line and then tighten it.

NOTE: The movable range of laser line is factory adjusted within 1 mm from the side surface of saw blade.

Cleaning the laser light lens

The laser light becomes hard to see as the lens for the laser light gets dirty. Clean the lens for laser light periodically.

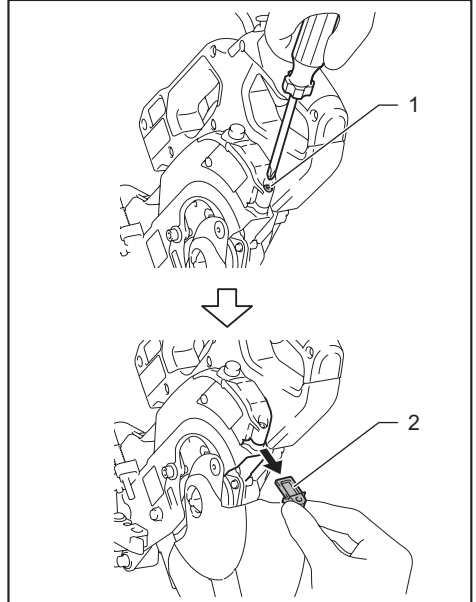

- 1. Screw 2. Lens

Remove the battery cartridge. Loosen the screw and pull out the lens. Clean the lens gently with a damp soft cloth.

NOTICE: Do not remove the screw which secures the lens. If the lens does not come out, loosen the screw further.

NOTICE: Do not use solvents or any petroleum-based cleaners on the lens.

After use

After use, wipe off chips and dust adhering to the tool with a cloth or the like. Keep the blade guard clean according to the directions in the previously mentioned in the section for the blade guard. Lubricate the sliding portions with machine oil to prevent rust.

OPTIONAL ACCESSORIES

⚠ WARNING: These Makita accessories or attachments are recommended for use with your Makita tool specified in this manual. The use of any other accessories or attachments may result in serious personal injury.

⚠ WARNING: Only use the Makita accessory or attachment for its stated purpose. Misuse of an accessory or attachment may result in serious personal injury.

If you need any assistance for more details regarding these accessories, ask your local Makita Service Center.

- Carbide-tipped saw blades
- Vertical vise
- Dust bag
- Triangular rule
- Hex wrench
- Hex wrench (for laser adjustment)
- Sub base set
- Makita genuine battery and charger

NOTE: Some items in the list may be included in the tool package as standard accessories. They may differ from country to country.

Makita Corporation
3-11-8, Sumiyoshi-cho,
Anjo, Aichi 446-8502 Japan
www.makita.com

885740-922 EN 20191022
