

INSTRUCTION MANUAL



Portable Cut-Off

LW1400

LW1401

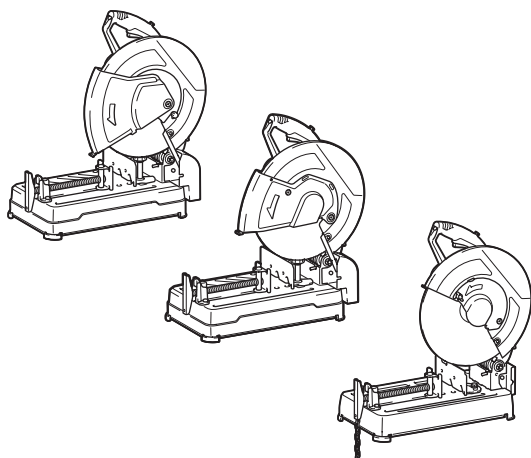

DOUBLE INSULATION



Read before use.

SPECIFICATIONS

Model:		LW1400	LW1401
Wheel diameter		355 mm	
Hole diameter		25.4 mm	
No load speed		3,800 min ⁻¹	
Dimensions (L x W x H)	With European type safety guard	530 mm x 295 mm x 640 mm	500 mm x 295 mm x 640 mm
	With safety guard other than European type	530 mm x 290 mm x 640 mm	500 mm x 290 mm x 620 mm
Net weight	With European type safety guard and under cover	18.7 kg	18.3 kg
Safety class		II/III	

- Due to our continuing program of research and development, the specifications herein are subject to change without notice.
- Specifications may differ from country to country.
- Weight according to EPTA-Procedure 01/2003
- The shape and weight vary depending on the specifications which differ country to country.

Symbols

The following show the symbols used for the equipment. Be sure that you understand their meaning before use.



Wear safety glasses.



Read instruction manual.



DOUBLE INSULATION



Only for EU countries
Do not dispose of electric equipment together with household waste material! In observance of the European Directive, on Waste Electric and Electronic Equipment and its implementation in accordance with national law, electric equipment that have reached the end of their life must be collected separately and returned to an environmentally compatible recycling facility.

Intended use

The tool is intended for cutting in ferrous materials with appropriate abrasive cut-off wheel. Follow all laws and regulations regarding dust and work area health and safety in your country.

Power supply

The tool should be connected only to a power supply of the same voltage as indicated on the nameplate, and can only be operated on single-phase AC supply. They are double-insulated and can, therefore, also be used from sockets without earth wire.

General power tool safety warnings

⚠ WARNING: Read all safety warnings, instructions, illustrations and specifications provided with this power tool. Failure to follow all instructions listed below may result in electric shock, fire and/or serious injury.

Save all warnings and instructions for future reference.

The term "power tool" in the warnings refers to your mains-operated (corded) power tool or battery-operated (cordless) power tool.

Work area safety

1. **Keep work area clean and well lit.** Cluttered or dark areas invite accidents.
2. **Do not operate power tools in explosive atmospheres, such as in the presence of flammable liquids, gases or dust.** Power tools create sparks which may ignite the dust or fumes.
3. **Keep children and bystanders away while operating a power tool.** Distractions can cause you to lose control.

Electrical Safety

1. **Power tool plugs must match the outlet. Never modify the plug in any way. Do not use any adapter plugs with earthed (grounded) power tools.** Unmodified plugs and matching outlets will reduce risk of electric shock.
2. **Avoid body contact with earthed or grounded surfaces, such as pipes, radiators, ranges and refrigerators.** There is an increased risk of electric shock if your body is earthed or grounded.
3. **Do not expose power tools to rain or wet conditions.** Water entering a power tool will increase the risk of electric shock.
4. **Do not abuse the cord. Never use the cord for carrying, pulling or unplugging the power tool. Keep cord away from heat, oil, sharp edges or moving parts.** Damaged or entangled cords increase the risk of electric shock.

5. **When operating a power tool outdoors, use an extension cord suitable for outdoor use.** Use of a cord suitable for outdoor use reduces the risk of electric shock.
6. **If operating a power tool in a damp location is unavoidable, use a residual current device (RCD) protected supply.** Use of an RCD reduces the risk of electric shock.
7. **Use of power supply via an RCD with a rated residual current of 30 mA or less is always recommended.**

Personal Safety

1. **Stay alert, watch what you are doing and use common sense when operating a power tool. Do not use a power tool while you are tired or under the influence of drugs, alcohol or medication.** A moment of inattention while operating power tools may result in serious personal injury.
2. **Use personal protective equipment. Always wear eye protection.** Protective equipment such as a dust mask, non-skid safety shoes, hard hat or hearing protection used for appropriate conditions will reduce personal injuries.
3. **Prevent unintentional starting. Ensure the switch is in the off-position before connecting to power source and/or battery pack, picking up or carrying the tool.** Carrying power tools with your finger on the switch or energising power tools that have the switch on invites accidents.
4. **Remove any adjusting key or wrench before turning the power tool on.** A wrench or a key left attached to a rotating part of the power tool may result in personal injury.
5. **Do not overreach. Keep proper footing and balance at all times.** This enables better control of the power tool in unexpected situations.
6. **Dress properly. Do not wear loose clothing or jewellery. Keep your hair and clothing away from moving parts.** Loose clothes, jewellery or long hair can be caught in moving parts.
7. **If devices are provided for the connection of dust extraction and collection facilities, ensure these are connected and properly used.** Use of dust collection can reduce dust-related hazards.
8. **Do not let familiarity gained from frequent use of tools allow you to become complacent and ignore tool safety principles.** A careless action can cause severe injury within a fraction of a second.

Power tool use and care

1. **Do not force the power tool. Use the correct power tool for your application.** The correct power tool will do the job better and safer at the rate for which it was designed.
2. **Do not use the power tool if the switch does not turn it on and off.** Any power tool that cannot be controlled with the switch is dangerous and must be repaired.
3. **Disconnect the plug from the power source and/or remove the battery pack, if detachable, from the power tool before making any adjustments, changing accessories, or storing power tools.** Such preventive safety measures reduce the risk of starting the power tool accidentally.

4. **Store idle power tools out of the reach of children and do not allow persons unfamiliar with the power tool or these instructions to operate the power tool.** Power tools are dangerous in the hands of untrained users.
5. **Maintain power tools and accessories. Check for misalignment or binding of moving parts, breakage of parts and any other condition that may affect the power tool's operation. If damaged, have the power tool repaired before use.** Many accidents are caused by poorly maintained power tools.
6. **Keep cutting tools sharp and clean.** Properly maintained cutting tools with sharp cutting edges are less likely to bind and are easier to control.
7. **Use the power tool, accessories and tool bits etc. in accordance with these instructions, taking into account the working conditions and the work to be performed.** Use of the power tool for operations different from those intended could result in a hazardous situation.
8. **Keep handles and grasping surfaces dry, clean and free from oil and grease.** Slippery handles and grasping surfaces do not allow for safe handling and control of the tool in unexpected situations.

Service

1. **Have your power tool serviced by a qualified repair person using only identical replacement parts.** This will ensure that the safety of the power tool is maintained.
2. **Follow instruction for lubricating and changing accessories.**

Cut-off machine safety warnings

1. **Position yourself and bystanders away from the plane of the rotating wheel.** The guard helps to protect the operator from broken wheel fragments and accidental contact with wheel.
2. **Use only bonded reinforced cut-off wheels for your power tool.** Just because an accessory can be attached to your power tool, it does not assure safe operation.
3. **The rated speed of the accessory must be at least equal to the maximum speed marked on the power tool.** Accessories running faster than their rated speed can break and fly apart.
4. **Wheels must be used only for recommended applications. For example: do not grind with the side of a cut-off wheel.** Abrasive cut-off wheels are intended for peripheral grinding, side forces applied to these wheels may cause them to shatter.
5. **Always use undamaged wheel flanges that are of correct diameter for your selected wheel.** Proper wheel flanges support the wheel thus reducing the possibility of wheel breakage.
6. **The outside diameter and the thickness of your accessory must be within the capacity rating of your power tool.** Incorrectly sized accessories cannot be adequately guarded or controlled.

7. **The arbour size of wheels and flanges must properly fit the spindle of the power tool.** Wheels and flanges with arbour holes that do not match the mounting hardware of the power tool will run out of balance, vibrate excessively and may cause loss of control.
8. **Do not use damaged wheels. Before each use, inspect the wheels for chips and cracks. If the power tool or wheel is dropped, inspect for damage or install an undamaged wheel. After inspecting and installing the wheel, position yourself and bystanders away from the plane of the rotating wheel and run the power tool at maximum no load speed for one minute.** Damaged wheels will normally break apart during this test time.
9. **Wear personal protective equipment. Depending on application, use face shield, safety goggles or safety glasses. As appropriate, wear dust mask, hearing protectors, gloves and shop apron capable of stopping small abrasive or workpiece fragments.** The eye protection must be capable of stopping flying debris generated by various operations. The dust mask or respirator must be capable of filtrating particles generated by your operation. Prolonged exposure to high intensity noise may cause hearing loss.
10. **Keep bystanders a safe distance away from work area. Anyone entering the work area must wear personal protective equipment.** Fragments of workpiece or of a broken wheel may fly away and cause injury beyond immediate area of operation.
11. **Position the cord clear of the spinning accessory.** If you lose control, the cord may be cut or snagged and your hand or arm may be pulled into the spinning wheel.
12. **Regularly clean the power tool's air vents.** The motor's fan can draw the dust inside the housing and excessive accumulation of powdered metal may cause electrical hazards.
13. **Do not operate the power tool near flammable materials. Do not operate the power tool while placed on a combustible surface such as wood.** Sparks could ignite these materials.
14. **Do not use accessories that require liquid coolants.** Using water or other liquid coolants may result in electrocution or shock.

Kickback and related warnings

Kickback is a sudden reaction to a pinched or snagged rotating wheel. Pinching or snagging causes rapid stalling of the rotating wheel which in turn causes the uncontrolled cutting unit to be forced upwards toward the operator.

For example, if an abrasive wheel is snagged or pinched by the workpiece, the edge of the wheel that is entering into the pinch point can dig into the surface of the material causing the wheel to climb out or kick out. Abrasive wheels may also break under these conditions.

Kickback is the result of power tool misuse and/or incorrect operating procedures or conditions and can be avoided by taking proper precautions as given below.

1. **Maintain a firm grip on the power tool and position your body and arm to allow you to resist kickback forces.** The operator can control upward kickback forces, if proper precautions are taken.
2. **Do not position your body in line with the rotating wheel.** If kickback occurs, it will propel the cutting unit upwards toward the operator.
3. **Do not attach a saw chain, woodcarving blade, segmented diamond wheel with a peripheral gap greater than 10 mm or toothed saw blade.** Such blades create frequent kickback and loss of control.
4. **Do not "jam" the wheel or apply excessive pressure. Do not attempt to make an excessive depth of cut.** Overstressing the wheel increases the loading and susceptibility to twisting or binding of the wheel in the cut and the possibility of kickback or wheel breakage.
5. **When the wheel is binding or when interrupting a cut for any reason, switch off the power tool and hold the cutting unit motionless until the wheel comes to a complete stop. Never attempt to remove the wheel from the cut while the wheel is in motion otherwise kickback may occur.** Investigate and take corrective action to eliminate the cause of wheel binding.
6. **Do not restart the cutting operation in the workpiece. Let the wheel reach full speed and carefully re-enter the cut.** The wheel may bind, walk up or kickback if the power tool is restarted in the workpiece.
7. **Support any oversized workpiece to minimize the risk of wheel pinching and kickback.** Large workpieces tend to sag under their own weight. Supports must be placed under the workpiece near the line of cut and near the edge of the workpiece on both sides of the wheel.

Additional safety warnings

1. **Watch out for flying sparks when operating.** They can cause injury or ignite combustible materials.
2. **Secure work. Use clamps or a vise to hold work when practical.** It's safer than using your hand and it frees both hands to operate tool.
3. **Secure the wheel carefully.**
4. **Be careful not to damage the spindle, flanges (especially the installing surface) or bolt, or the wheel itself might break.**
5. **Keep guards in place and in working order.**
6. **Hold the handle firmly.**
7. **Keep hands away from rotating parts.**
8. **Make sure the wheel is not contacting the work-piece before the switch is turned on.**
9. **Before each use, watch for flutter or excessive vibration that might be caused by poor installation or a poorly balanced wheel.**
10. **Remove material or debris from the area that might be ignited by sparks. Be sure that others are not in the path of the sparks. Keep a proper, charged fire extinguisher closely available.**

11. If the wheel stops during the operation, makes an odd noise or begins to vibrate, switch off the tool immediately.
12. Always switch off and wait for the wheel to come to a complete stop before removing, securing workpiece, working vise, changing work position, angle or the wheel itself.
13. Do not touch the workpiece immediately after operation; it is extremely hot and could burn your skin.
14. Store wheels in a dry location only.

SAVE THESE INSTRUCTIONS.

INSTALLATION

⚠WARNING: This tool produces spark when cutting a workpiece. Do not install this tool in the place in which flammable and/or explosive materials might be ignited by the spark from the tool. Also make sure that there is no such material near the tool before starting the operation.

Securing the base

This tool should be bolted with two bolts to a level and stable surface using the bolt holes provided in the tool's base. This will help prevent tipping over and possible personal injury.

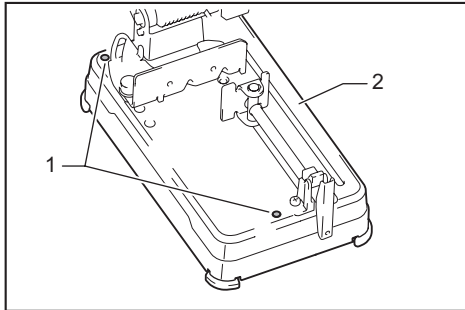

► 1. Bolt holes 2. Base

FUNCTIONAL DESCRIPTION

⚠CAUTION: Always be sure that the tool is switched off and unplugged before adjusting or checking function on the tool.

Unlocking/locking tool head

The tool head can be locked. Always lock the tool head when not in use or carrying.

For LW1400

To unlock, depress the tool head slightly and push the lock pin. To lock, return the lock pin while holding down the tool head.

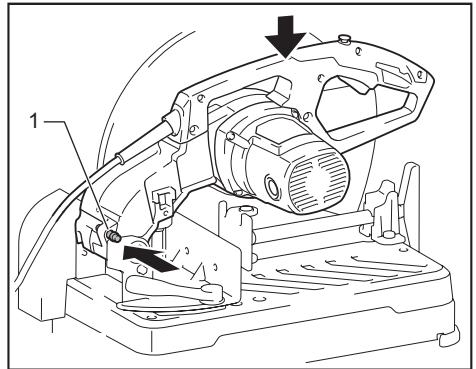

► 1. Lock pin

For LW1401

Unhook the lock chain from the hook. Always hook the lock chain to the hook when not in use.

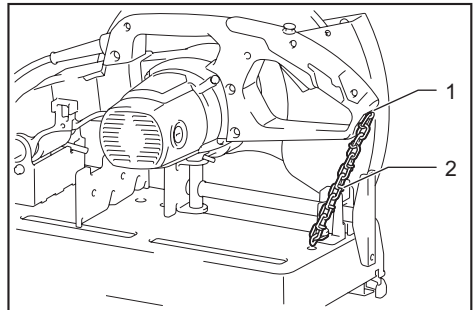

► 1. Hook 2. Lock chain

Switch action

⚠WARNING: Before plugging in the tool, always check to see that the switch trigger actuates properly and returns to the "OFF" position when released.

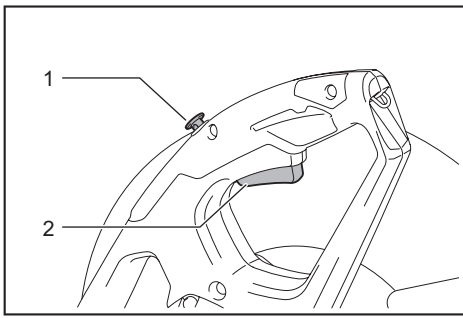

► 1. Lock button / Lock-off button 2. Switch trigger

For tool with lock button

To start the tool, simply pull the switch trigger. Release the switch trigger to stop. For continuous operation, pull the switch trigger, push in the lock button and then release the switch trigger. To stop the tool from the locked position, pull the trigger fully, then release it.

⚠ CAUTION: Switch can be locked in "ON" position for ease of operator comfort during extended use. Apply caution when locking tool in "ON" position and maintain firm grasp on tool.

For tool with lock-off button

To prevent the switch trigger from being accidentally pulled, a lock-off button is provided. To start the tool, press the lock-off button and pull the switch trigger. Release the switch trigger to stop.

⚠ WARNING: NEVER defeat the lock-off button by taping down or some other means. A switch with a negated lock-off button may result in unintentional operation and serious personal injury.

⚠ WARNING: NEVER use the tool if it runs when you simply pull the switch trigger without pressing the lock-off button. A switch in need of repair may result in unintentional operation and serious personal injury. Return tool to a Makita service center for proper repairs BEFORE further usage.

NOTICE: Do not pull the switch trigger hard without pressing in the lock-off button. This can cause switch breakage.

Interval between vise and guide plate

⚠ CAUTION: After adjusting the interval between the vise and the guide plate, make sure that the guide plate is properly secured. Insufficient fixing may result in personal injury.

The following interval settings of the vise are available:

- 0 - 170 mm (original setting)
- 35 - 205 mm
- 70 - 240 mm

If your work requires different setting, proceed as follows to change the spacing or interval.

For LW1400

Loosen the screw on the guide plate. Move the guide plate to the desired position then tighten the screw.

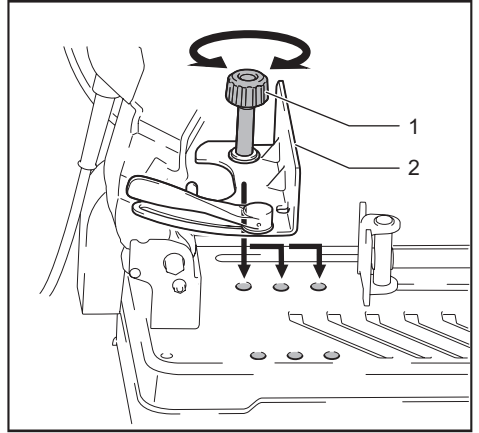

► 1. Screw 2. Guide plate

For LW1401

Remove the two hex bolts using a socket wrench. Move the guide plate to the desired position and secure it with the hex bolts.

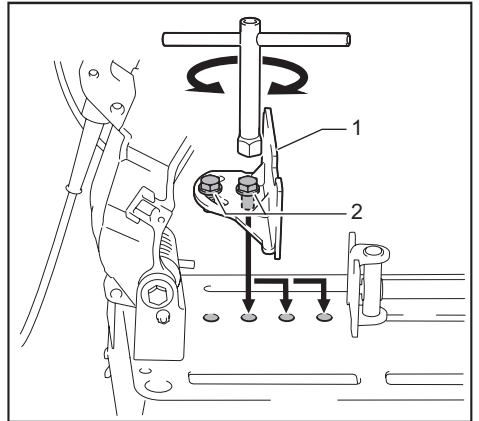

► 1. Guide plate 2. Hex bolts

Cutting angle adjustment

⚠ CAUTION: After adjusting the angle of the guide plate, make sure that the guide plate is properly secured. Insufficient fixing may result in personal injury.

⚠ CAUTION: Do not operate the tool when the material is not firmly secured with the vise because of the cutting angle.

For LW1400

Turn the lever counterclockwise. Move the guide plate to the desired angle and fully tighten the lever.

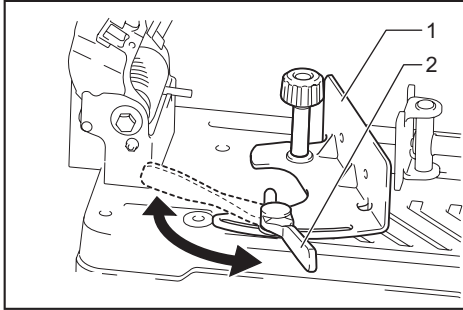

► 1. Guide plate 2. Lever

For LW1401

NOTICE: When performing right miter cut, always set the guide plate at 0 - 170 mm position. Setting at the 35 - 205 mm or 70 - 240 mm position hinders the movement of stopper plate, which results in a failure cut.

Loosen the two hex bolts using a socket wrench. Turn the guide plate to the desired angle and secure it with the hex bolts. Be careful not to move the set angle while securing the hex bolts.

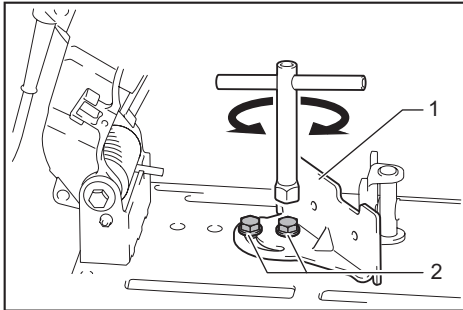

► 1. Guide plate 2. Hex bolts

NOTE: The scale on the guide plate is only a rough indication. For more accurate angle, use a protractor or triangle ruler. Keep the handle down so that the cut-off wheel extends into the base. At the same time, adjust the angle between the guide plate and the cut-off wheel with a protractor or triangle ruler.

Spark guard adjustment

For LW1401 only (country specific)

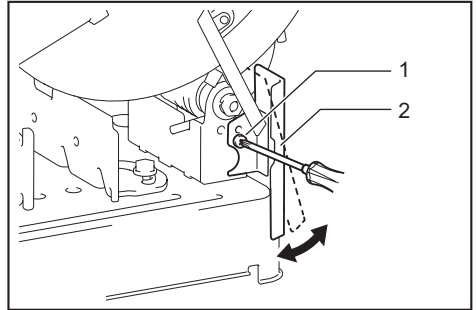

► 1. Screw 2. Spark guard

The spark guard is factory-installed with its lower edge contacting the base. Operating the tool in this position will cause many sparks to fly around. Loosen the screw and adjust the spark guard to a position at which minimum sparks will fly around.

Stopper plate

For LW1401 only (country specific)

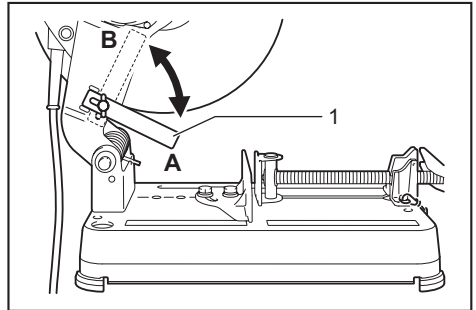

► 1. Stopper plate

The stopper plate prevents the cut-off wheel from contacting the workbench or floor. When a new cut-off wheel is installed, set the stopper plate to position (A). When the cut-off wheel wears down to the extent that the lower portion of the workpiece is left uncut, set the stopper plate to position (B) to allow increased cutting capacity with a worn down wheel.

ASSEMBLY

CAUTION: Always be sure that the tool is switched off and unplugged before carrying out any work on the tool.

Opening center cap type safety guard

Country specific

For the tools equipped with center cap type safety guard, loosen the clamping screw first then raise the guard.

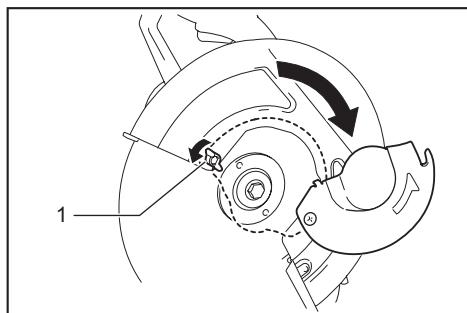

► 1. Clamping screw

Opening European type safety guard

Country specific

For the tools equipped with European type safety guard, loosen the clamping screw first then open the guard as shown.

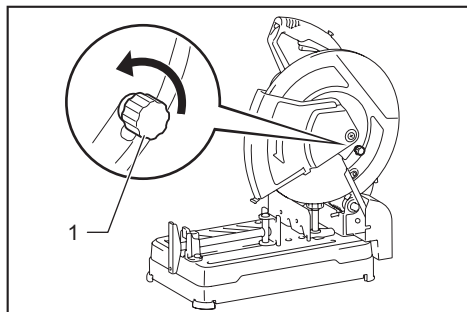

► 1. Clamping screw

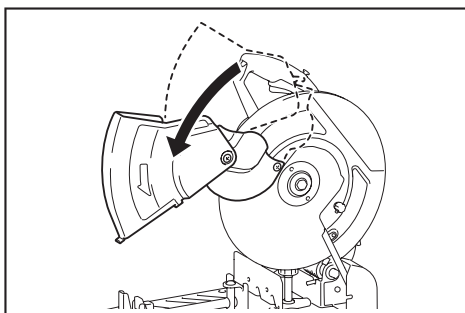
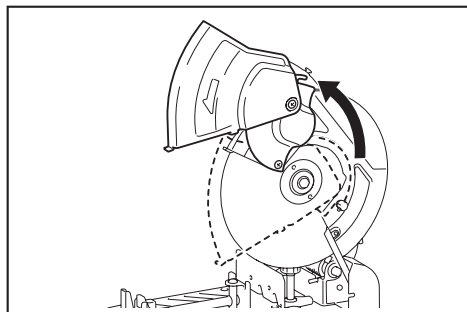

Removing or installing cut-off wheel

CAUTION: Be sure to tighten the toolless clamp or hex bolt securely. Insufficient tightening may result in severe injury. When tightening the hex bolt, use the socket wrench provided with the tool to assure proper tightening.

CAUTION: Always use only the proper inner and outer flanges which are provided with the tool.

CAUTION: Always lower the safety guard after replacing the wheel.

CAUTION: Wear gloves when handling wheels.

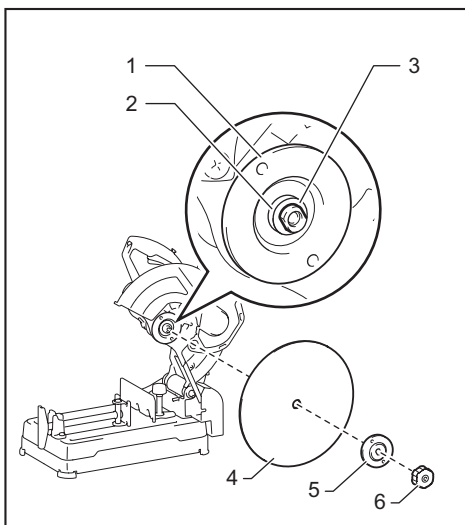

► 1. Inner flange 2. Ring 3. O-ring 4. Cut-off wheel
5. Outer flange 6. Toolless clamp / Hex bolt

For LW1400

Raise the safety guard. Turn the toolless clamp counterclockwise while holding down the shaft lock. Then remove the toolless clamp, outer flange and cut-off wheel. When removing the cut-off wheel, do not remove the inner flange as well as the ring and O-ring.

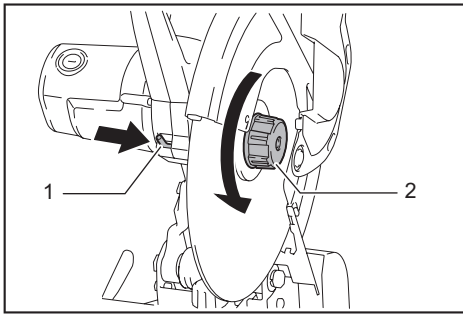

► 1. Shaft lock 2. Toolless clamp

To install the cut-off wheel, follow the removal procedures in reverse. Make sure to fit the hole of cut-off wheel to the ring and return the safety guard.

For LW1401

Raise the safety guard. Turn the hex bolt counterclockwise using a socket wrench while holding down the shaft lock. Then remove the hex bolt, outer flange and wheel.

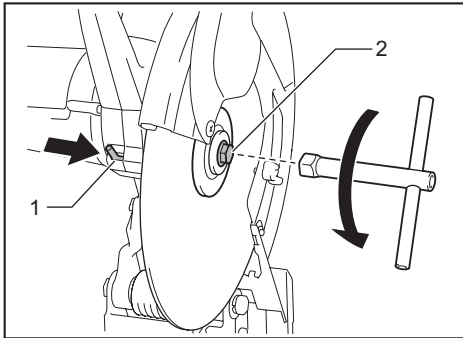

► 1. Shaft lock 2. Hex bolt

To install the wheel, follow the removal procedures in reverse. Make sure to fit the hole of cut-off wheel to the ring and return the safety guard.

OPERATION



CAUTION: Proper handle pressure during cutting and maximum cutting efficiency can be determined by the amount of sparks that is produced while cutting. Do not force the cut by applying excessive pressure on the handle. Reduced cutting efficiency, premature wheel wear, as well as, possible damage to the tool, cut-off wheel or workpiece may result.

Hold the handle firmly. Switch on the tool and wait until the wheel attains full speed before lowering gently into the cut. When the wheel contacts the workpiece, gradually bear down on the handle to perform the cut. When the cut is completed, switch off the tool and **wait until the wheel has come to a complete stop** before returning the handle to the fully elevated position.

Cutting capacity

Maximum cutting capacity varies depending on the cutting angle and workpiece shape.

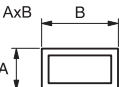
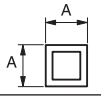
Max. cutting capacity with a brand-new cut-off wheel

Cutting angle / Workpiece shape	90°	45°
	127 mm	127 mm
	115 x 130 mm 102 x 194 mm 70 x 233 mm	115 x 103 mm
	119 x 119 mm	106 x 106 mm
	137 x 137 x 10 mm	100 x 100 x 10 mm

Securing workpiece

CAUTION: Always place the thread holder on the shaft threads when securing the workpiece. Failure to do so may result in insufficient securing of the workpiece. This could cause the workpiece to be ejected or cause a dangerous breakage of the wheel.

While the thread holder is lifted, the vise plate can be moved in and out quickly. To grip a workpiece, push the handle until the vise plate contacts the workpiece then return the thread holder. Turn the handle clockwise until the workpiece is securely retained.

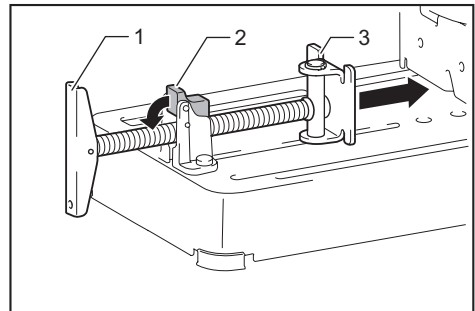

► 1. Handle 2. Thread holder 3. Vise plate

When the cut-off wheel has worn down considerably, place a spacer block behind the workpiece as shown in the figure. You can more efficiently utilize the worn wheel by using the mid point on the periphery of the wheel to cut the workpiece. Use a sturdy and non-flammable material for a spacer block.

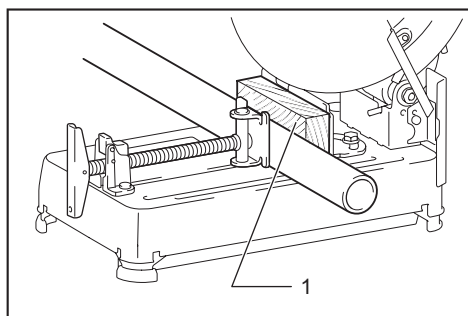

► 1. Spacer block

When cutting workpieces over 85 mm wide at an angle, attach a straight piece of wood (spacer) over 190 mm long x 45 mm wide to the guide plate as shown in the figure. Attach this spacer with screws through the holes in the guide plate. Make sure that the cut-off wheel does not contact the spacer when the tool head is depressed.

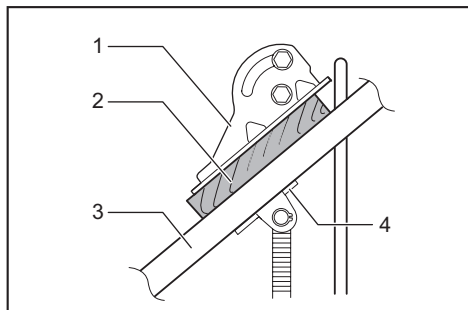

► 1. Guide plate 2. Spacer block (over 190 mm long x 45 mm wide) 3. Workpiece (over 85 mm wide) 4. Vise plate

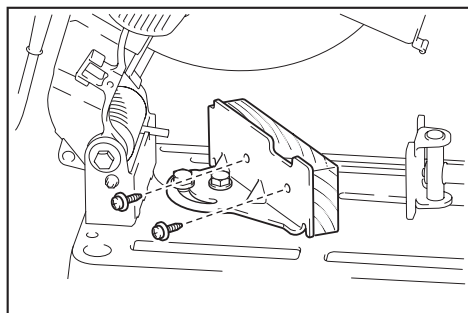

When the cut-off wheel has worn down, raise the cutting position by putting a spacer block which is slightly narrower than the workpiece as shown in the figure. This will help you to utilize the wheel economically.

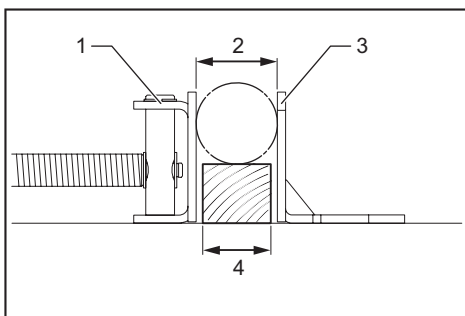

► 1. Vise plate 2. Workpiece diameter 3. Guide plate 4. Spacer block width

Long workpieces must be supported by blocks on either side so that it will be level with the base top. Use non-flammable material for supporting blocks.

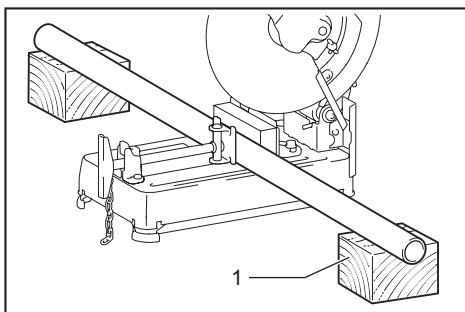

► 1. Supporting block

Carrying tool

Fold down the tool head and lock it. Hold the handle when carrying.

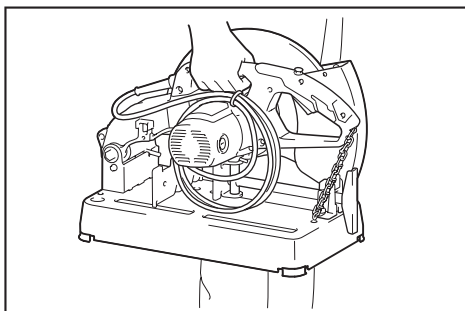

MAINTENANCE

CAUTION: Always be sure that the tool is switched off and unplugged before attempting to perform inspection or maintenance.

NOTICE: Never use gasoline, benzine, thinner, alcohol or the like. Discoloration, deformation or cracks may result.

- Abrasive cut-off wheels
- Socket wrench (for LW1401 only)

NOTE: Some items in the list may be included in the tool package as standard accessories. They may differ from country to country.

Replacing carbon brushes

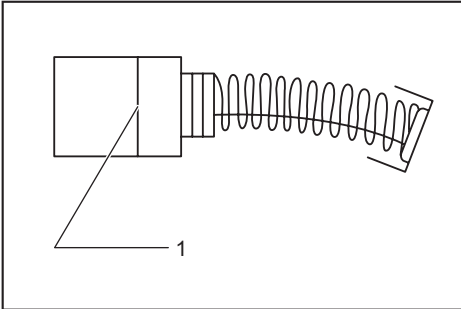

- 1. Limit mark

Check the carbon brushes regularly. Replace them when they wear down to the limit mark. Keep the carbon brushes clean and free to slip in the holders. Both carbon brushes should be replaced at the same time. Use only identical carbon brushes.

1. Use a screwdriver to remove the brush holder caps.
2. Take out the worn carbon brushes, insert the new ones and secure the brush holder caps.

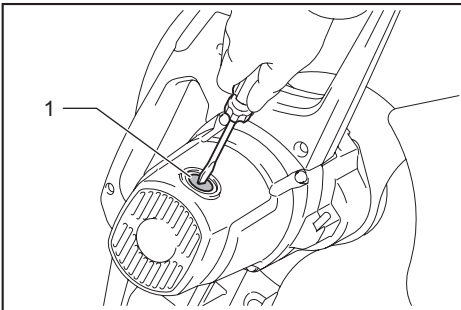

- 1. Brush holder cap

OPTIONAL ACCESSORIES

⚠ CAUTION: These accessories or attachments are recommended for use with your Makita tool specified in this manual. The use of any other accessories or attachments might present a risk of injury to persons. Only use accessory or attachment for its stated purpose.

If you need any assistance for more details regarding these accessories, ask your local Makita Service Center.

Makita Corporation
3-11-8, Sumiyoshi-cho,
Anjo, Aichi 446-8502 Japan
www.makita.com

885456A931 EN 20160704
