



HK

HONG KONG

Diagram / Parts List

LS0816F

216MM SLIDE COMPOUND MITER SAW



(HK) LS0816F / 216MM SLIDE COMPOUND MITER SAW

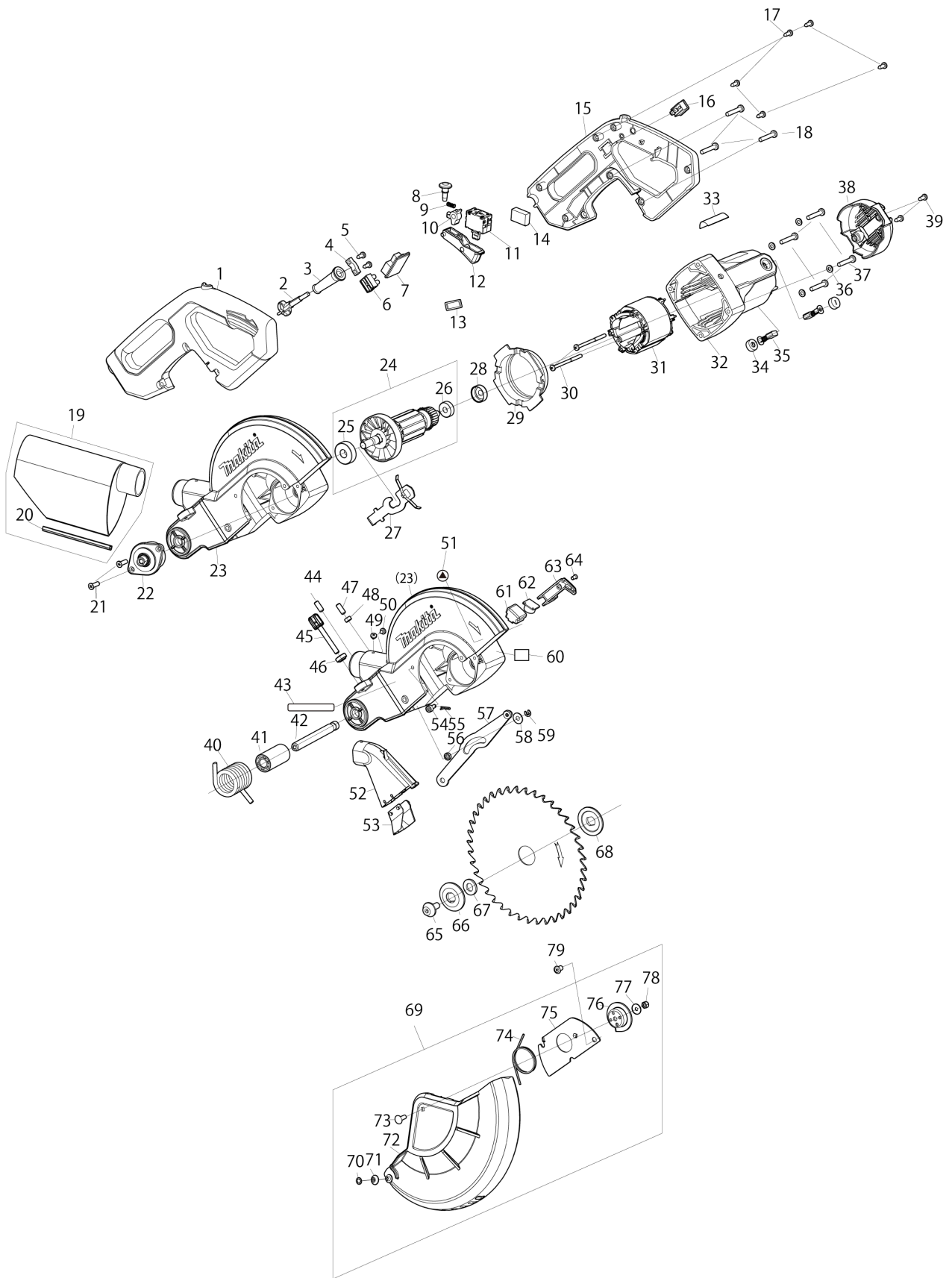

(HK) LS0816F / 216MM SLIDE COMPOUND MITER SAW

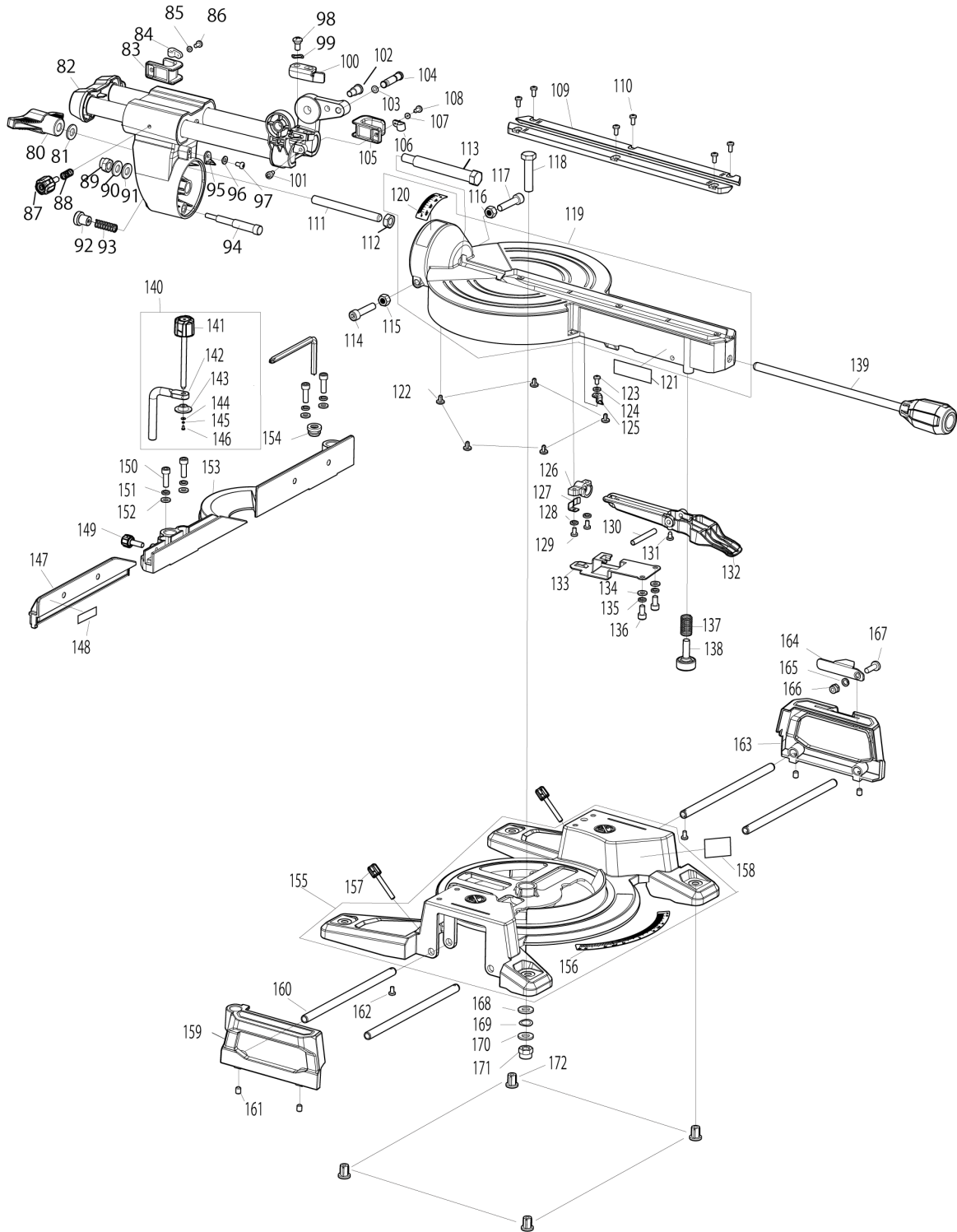

HK

HONG KONG

LS0816F / 216MM SLIDE COMPOUND MITER SAW

Item	Sub	Parts No.	Parts Description	Qty	I/C	E/C No.	Close No.	Remark
001		JM00000583	HANDLE LEFT	1				
002		JM23000152	PW SUPPLY CORD H05VV-F 1-2 BSI	1				
003		JM23100165	CORD GUARD S	1				
004		JM00000584	CORD CLAMP	1				
005		JM00000548	TAPPING SCREW ST4.2X13	2				
006		JM23100171	TERMINAL BLOCK 2P	1				
007		JM00000573	PW CIRCUIT FOR LED LAMP	1				
008		JM23100177	LOCK OFF BUTTON	1				
009		JM00000582	COMPRESSION SPRING	1				
010		JM00000581	LOCK OFF LINK ROCKER	1				
011		JM00000576	SWITCH	1				
012		JM00000575	SWITCH LEVER	1				
013		JM00000578	FERRITE RING	1				
014		JM23100169	CAPACITOR	1				
015		JM00000580	HANDLE RIGHT	1				
016		JM00000579	LAMP SWITCH	1				
017		JM00000548	TAPPING SCREW ST4.2X13	5				
018		JM00000551	PAN HEAD SCREW M5X30	3				
019		JM00000535	DUST BAG ASSY	1				
	D10		INC. 20					
020		JM00000534	DUST BAG CLAMP	1				
021		JM27000317	FLAT HEAD SCREW M5X16	2				
022		JM00000542	SPINDLE GEAR ASSY	1				
023		JM00000527	UPPER BLADE GUARD COMP	1			Y09496	
023-1		JM00000698	UPPER BLADE GUARD COMP	1	X	Y09496		
024		JM23500001	ARMATURE ASSY (230V)	1			Y09442	
	D10		INC. 25,26				Y09442	
024-1		JM00000684	ARMATURE ASSY (230V)	1	X	Y09442		
	D10		INC. 25,26			Y09442		
025		JM23500137	BALL BEARING 6201	1				
026		JM23500111	BALL BEARING 608	1				
027		JM00000569	SPINDLE LOCK LEVER COMPLETE	1				
028		JM23500112	DAMPING RING	1				
029		JM00000556	BUFFLE PLATE	1				
030		JM00000555	SELF TAPPING SCREW ST4.2X65	2				
031		JM23500004	FIELD 230V	1			Y09445	
031-1		JM00000685	FIELD 230V	1	X	Y09445		
032		JM00000599	MOTOR HOUSING ASSY	1				
033		JM00000563	NAME PLATE HK	1				
034		JM00000567	BRUSH CAP	2				
035		JM00000566	CARBON BRUSH 2PCS SET	1				
036		JM23100007	FLAT WASHER 5	4				
037		JM00000551	PAN HEAD SCREW M5X30	4				
038		JM00000549	MOTOR END COVER	1				
039		JM00000548	TAPPING SCREW ST4.2X13	2				
040		JM00000518	TORSION SPRING 41	1				
041		JM00000519	SPRING BUSH	1				
042		JM00000497	PIVOT SHAFT 12X107	1				
044		JM00000537	HEX SOCKET SET SCREW M6X16	1				
045		JM00000444	KNOB BOLT M6X46	1				
046		JM00000536	KNURLED NUT M6	1				
047		JM00000538	SET SCREW M6X18	1				
048		JM23100035	ANTI-LOOSEN RING	1				
049		JM00000539	TAPPING SCREW ST4.2X6.5	1				
050		JM00000539	TAPPING SCREW ST4.2X6.5	1				
051		JM00000589	CAUTION LABEL	1				
052		JM00000521	DUST PORT	1				
053		JM00000520	DUST CHUTE PLATE	1				
054		JM00000532	HEX SOCKET HEAD BOLT M6X18	1				
055		JM00000531	R-PIN 6	1				
056		JM23100098	LINK SLEEVE	1				
057		JM00000522	LINK PLATE COMP	1				
058		JM23100071	THIN FLAT WASHER 6	1				
059		JM00000525	STOP RING E-5	1				
061		JM00000540	LED LAMP BOX	1				

A:

Interchange

O : Yes

X : No

< : the new part can be substituted for the current.

> : the current part can be substituted for the new.

S : Interchangeable as a set.

HK

HONG KONG

LS0816F / 216MM SLIDE COMPOUND MITER SAW

Item	Sub	Parts No.	Parts Description	Qty	I/C	E/C No.	Close No.	Remark
062		JM00000541	LED LAMP COMP	1				
063		JM00000526	LED WIRE COVER	1				
064		JM23100065	PAN HEAD SCREW M4X8	1				
065		JM00000514	HEX SOCKET HEAD BOLT M8X20 LH	1				
066		JM23500038	BLADE FLANGE	1				
067		JM27000101	BLADE INNER LING 25.4	1				
068		JM23500038	BLADE FLANGE	1				
069		JM00000502	LOWER BLADE GUARD ASSY	1				
	D10		INC. 70-78					
070		JM00000503	PUSH NUT 5	1				
071		JM00000504	GUARD WHEEL	1				
072		JM00000506	LOWER BLADE GUARD	1				
073		JM00000505	SQUARE NECK BOLT M5X12	1				
074		JM00000507	TORSION SPRING 40	1				
075		JM00000508	GUARD FIX PLATE	1				
076		JM00000509	BOWL PLATE	1				
077		JM00000510	FLAT WASHER 5L	1				
078		JM23100141	HEX LOCK NUT 5	1				
079		JM00000530	STEPPED TRASS HEAD BOLT M6X10	1				
080		JM00000477	WING NUT M10	1				
081		JM23100010	FLAT WASHER 10	1				
082		JM00000485	SLIDING ARM ASSY	1				
083		JM00000501	CORD REEL HOOK	1				
084		JM00000500	CORD CLIP	1				
085		JM00000499	BIG FLAT WASHER 5	1				
086		JM00000498	PAN HEAD SCREW M5X16	1				
087		JM00000478	KNOB BOLT M6X20	1				
088		JM00000479	COMPRESSION SPRING 9X18	1				
089		JM23100009	HEX LOCK NUT M10	1				
090		JM23100010	FLAT WASHER 10	1				
091		JM23100010	FLAT WASHER 10	1				
092		JM00000480	KNOB NUT M5	1				
093		JM00000481	COMPRESSION SPRING 10X32	1				
094		JM00000483	BEVEL STEP STOPPER BOLT M5X18	1				
095		JM00000482	BEVEL SCALE POINTER	1				
096		JM23100016	FLAT WASHER 4	1				
097		JM23100065	PAN HEAD SCREW M4X8	1				
098		JM00000517	STEPPED PAN HEAD SCREW M6X10	1				
099		JM23100094	WAVE WASHER 8	1				
100		JM00000516	CUTTING DEPTH ADJUSTABLE PLATE	1				
101		JM00000495	STEPPED H.S.H.BOLT M6X10	1				
102		JM00000515	H.S.H. SPECIAL BOLT M10X10	1				
103		JM23100150	SEALING RING	1				
104		JM00000496	LOCK PIN	1				
105		JM00000501	CORD REEL HOOK	1				
106		JM00000500	CORD CLIP	1				
107		JM00000499	BIG FLAT WASHER 5	1				
108		JM00000498	PAN HEAD SCREW M5X16	1				
109		JM00000476	KERF BOARD	2				
110		JM23100033	PAN HEAD SCREW M4X12	6				
111		JM00000484	HEX SOCKET SCREW ROD M10X100	1				
112		JM23000015	HEX NUT M10	1				
113		JM00000467	CONNECTION SHAFT BOLT M10X20	1				
114		JM00000451	HEX SOCKET HEAD BOLT M8X35	1				
115		JM23000028	HEX. NUT M8	1				
116		JM23000028	HEX. NUT M8	1				
117		JM00000451	HEX SOCKET HEAD BOLT M8X35	1				
118		JM00000468	HEX BOLT M10X45	1				
119		JM00000469	TURN TABLE COMPLETE	1			Y09435	
	D10		INC. 120				Y09435	
119-1		JM00000681	TURN TABLE COMPLETE	1	<	Y09435		
	D10		INC. 120			Y09435		
120		JM00000470	SUPPORT ARM SCALE LABEL	1				
121		JM23180057	CAUTION LABEL	1				
122		JM00000453	SLIDING FOOT	5				

A:

Interchange
O : Yes
X : No
< : the new part can be substituted for the current.
> : the current part can be substituted for the new.
S : Interchangeable as a set.

