



HK

HONG KONG

Diagram / Parts List

CE003G

230MM CORDLESS POWER CUTTER



(HK) CE003G / 230MM CORDLESS POWER CUTTER

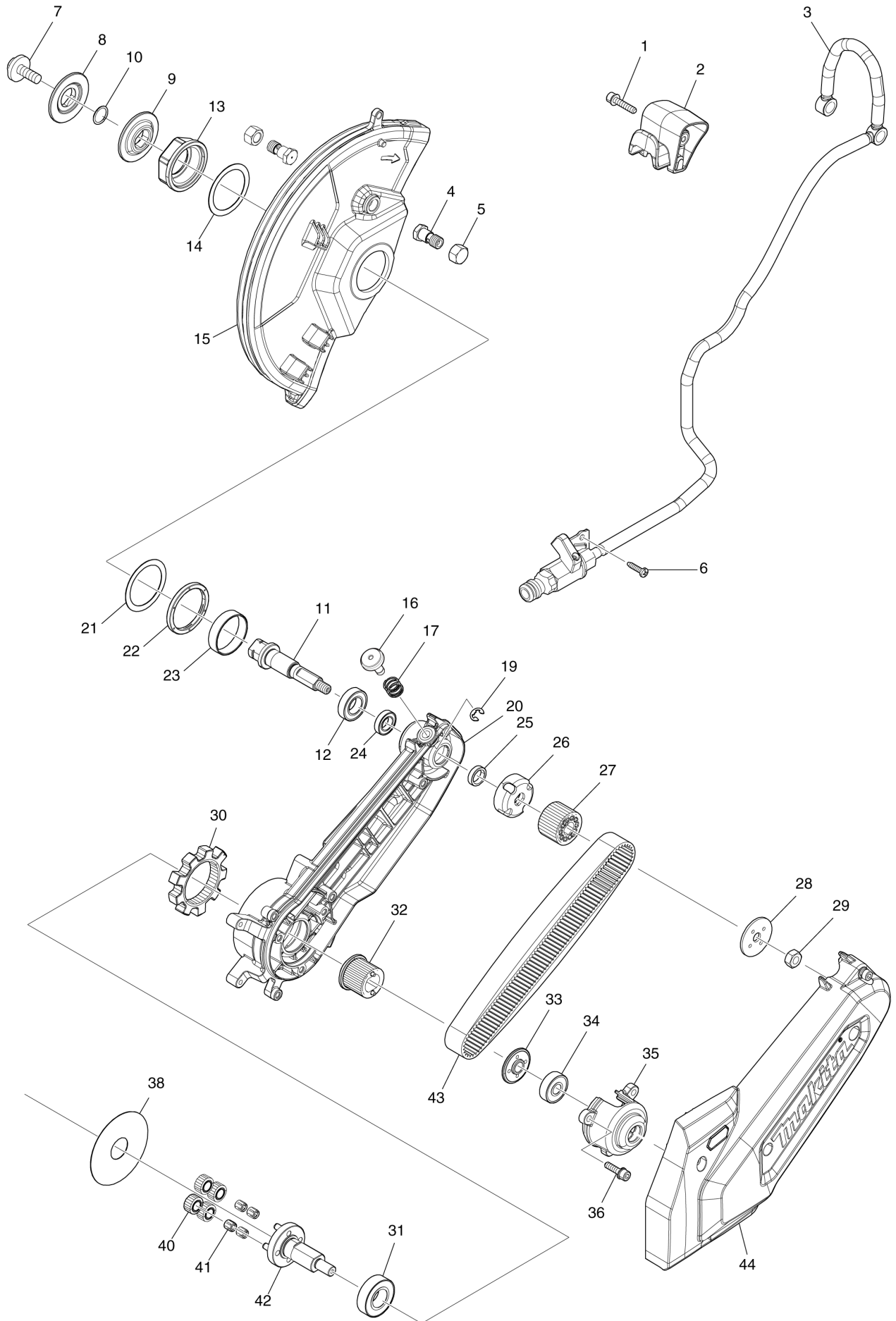

(HK) CE003G / 230MM CORDLESS POWER CUTTER

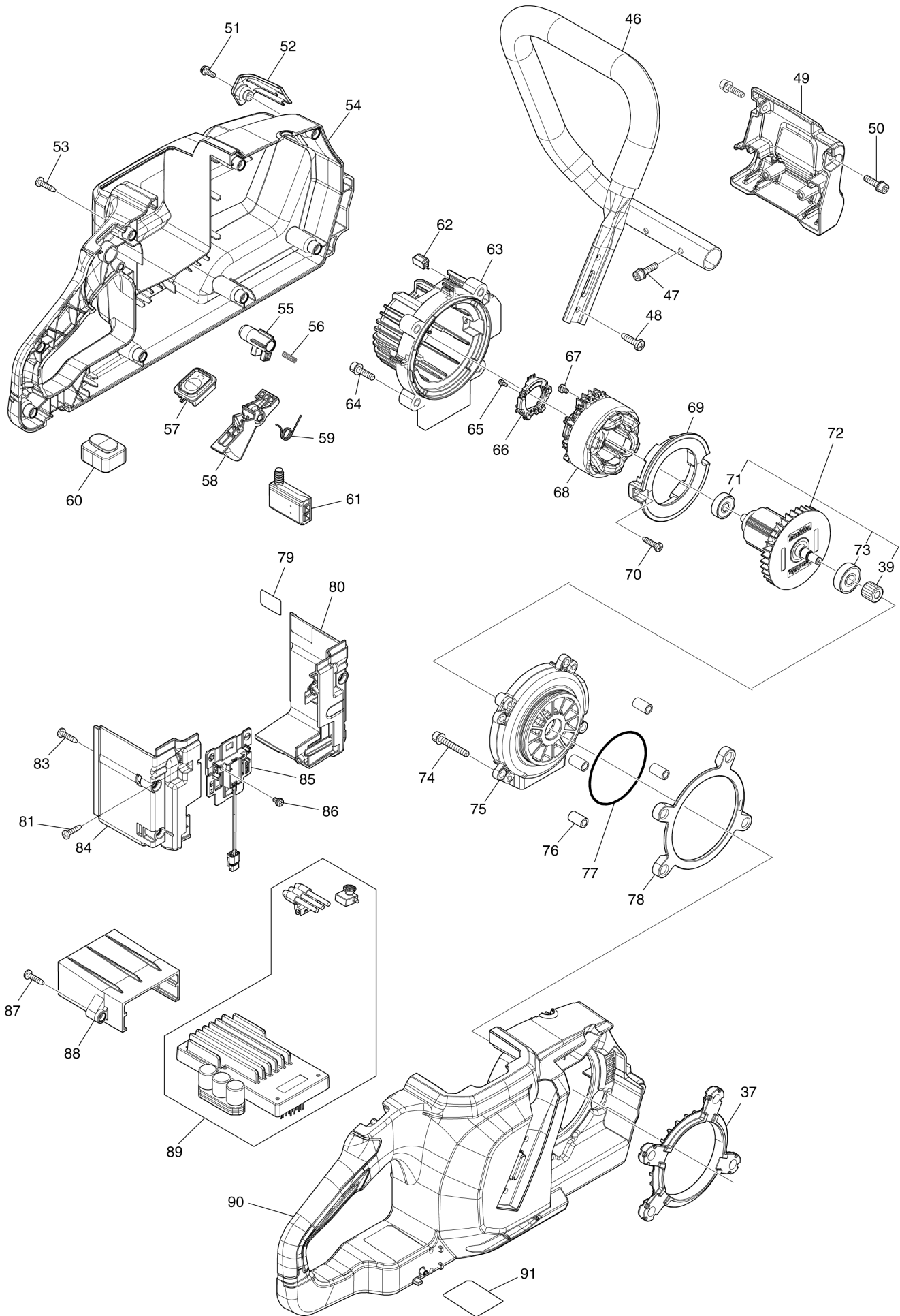

HK

HONG KONG

CE003G / 230MM CORDLESS POWER CUTTER

Item	Sub	Parts No.	Parts Description	Qty	I/C	E/C No.	Close No.	Remark
001		922243-3	HEX. SOCKET HEAD BOLT M5X25	1				
002		413Y26-7	WHEEL COVER GRIP	1				
003		122G28-1	HOSE ASSEMBLY	1				
004		265C26-9	HEX.BOLT M10X21	2				
005		252306-4	HEX.NUT M10	2				
006		266326-2	TAPPING SCREW 4X18	2				
007		266690-1	HEX. BOLT M8X25	1				
008		224604-6	OUTER FLANGE 46	1				
009		224605-4	INNER FLANGE 46	1				
010		213162-7	O RING 14	1				
011		327E57-9	SPINDLE	1				
012		211244-9	BALL BEARING 6902LLU	1				
013		312F61-7	BEARING RETAINER	1				
014		261178-6	POLYACETAL WASHER 38	1				
015		141X50-1	WHEEL COVER COMPETE	1				
	C10	8076P8-1	CAUTION LABEL	1				
016		137186-8	PIN CAP ASS'Y	1				
017		233089-5	COMPRESSION SPRING 12	1				
019		961012-7	STOP RING E-6	1				
020		312E99-6	CUTTING DEVICE	1				
021		261178-6	POLYACETAL WASHER 38	1				
022		422B46-2	RUBBER RING 39	1				
023		257A32-6	RING 35	1				
024		210245-4	BALL BEARING 6801LLU	1				
025		257A31-8	RING 12	1				
026		347C25-4	PULLY BOTTOM PLATE	1				
027		222212-7	PULLEY 21-30.7	1				
028		347C26-2	PULLEY PLATE 36	1				
029		931402-8	HEX. NUT M8	1				
030		227B45-7	INTERNAL GEAR 55	1				
031		210301-0	BALL BEARING 6003DDW	1				
032		222213-5	PULLEY 21-27.5	1				
033		327D38-7	PULLEY PLATE 32	1				
034		211092-6	BALL BEARING 629DDW	1				
035		312F02-3	PULLEY COVER	1				
036		922233-6	H.S.H.BOLT M5X20 WITH WR	3				
037		422B44-6	DAMPER A	1				
038		253599-6	FLAT WASHER 20	1				
039		227B43-1	SPUR GEAR 17	1				
040		227B44-9	SPUR GEAR 18	4				
041		212265-4	NEEDLE CAGE 508	4				
042		141V23-2	CARRIER COMPLETE	1				
043		225111-2	SYNCHRO BELT 20-500	1				
044		137110-1	BELT COVER ASSEMBLY	1				
	C10	265B09-3	H.S. HEAD BOLT M5X30 WITH WR	5				
046		327D37-9	FRONT GRIP 26	1				
047		922233-6	H.S.H.BOLT M5X20 WITH WR	2				
048		266420-0	TAPPING SCREW 5X20	2				
049		312F04-9	STAND SUPPORT	1				
050		922233-6	H.S.H.BOLT M5X20 WITH WR	2				
051		911118-1	PAN HEAD SCREW M4X12	1				
052		413Y18-6	LENS	1				
053		266326-2	TAPPING SCREW 4X18	8				
054		1830N5-4	HOUSING SET	1				
	D10		INC. 90					
055		413Y21-7	LOCK OFF BUTTON	1				
056		232444-8	COMPRESSION SPRING 4	1				
057		141V21-6	SWITCH CIRCUIT COMPLETE	1				
058		413Y20-9	SWITCH LEVER	1				
059		232854-9	TORSION SPRING 10	1				
060		422823-0	REAR FOOT	1				
061		632V44-0	SWITCH UNIT	1				
062		620N97-3	LED CIRCUIT	1				
063		413Y19-4	MOTOR HOUSING	1				
064		922233-6	H.S.H.BOLT M5X20 WITH WR	4				

Z:CE003GZ(N)

Interchange

O : Yes

X : No

< : the new part can be substituted for the current.

> : the current part can be substituted for the new.

S : Interchangeable as a set.

